

**KSP SERİSİ ELEKTRİK MOTORLU POMPA BOYUTLARI**

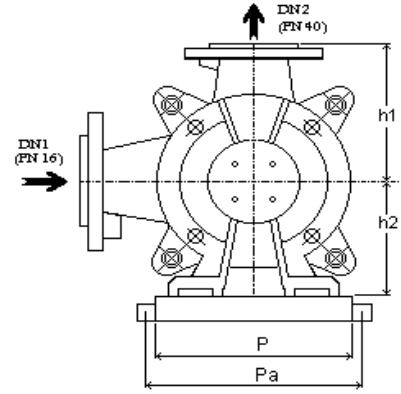
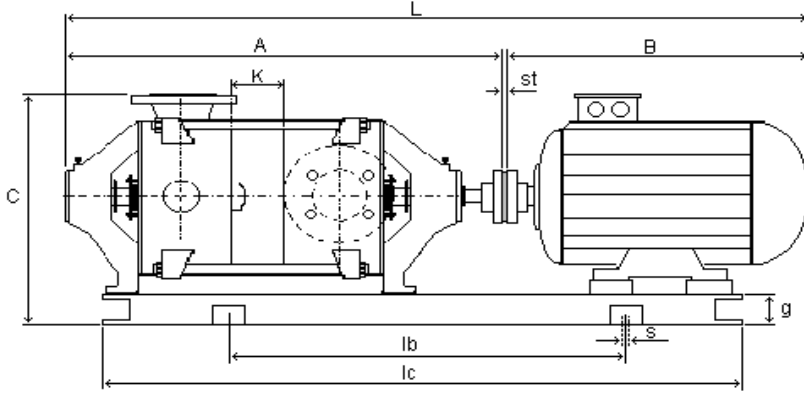

**2900 D/D**

| POMPA<br>TİPİ | Kad.<br>sayısı | MOTOR |        | FLANŞLAR |      | BOYUT ÖLÇÜLERİ (mm) |      |      |      |      |      |      |      |     |      |      |     |     | KAPLIN<br>ÖLÇ. (φ) | AĞIRLIK<br>(Kg.) |     |     |     |     |     |     |
|---------------|----------------|-------|--------|----------|------|---------------------|------|------|------|------|------|------|------|-----|------|------|-----|-----|--------------------|------------------|-----|-----|-----|-----|-----|-----|
|               |                | HP    | Gövde  | DN1      | DN2  | A                   | B    | C    | L    | lc   | lb   | s    | g    | K   | P    | Pa   | h1  | h2  |                    |                  | st  |     |     |     |     |     |
| KSP 32        | 2              | 4     | 100 L2 | 50       | 32   | 525                 | 375  | 350  | 930  | 790  | 390  | 18   | 65   | 45  | 200  | 260  | 153 | 132 | 30                 | 110              | 96  |     |     |     |     |     |
|               | 2              | 5,5   | 112 M2 |          |      |                     | 394  |      | 949  | 795  | 395  |      |      |     | 230  | 290  |     |     |                    |                  | 106 |     |     |     |     |     |
|               | 3              | 7,5   | 132 S2 |          |      | 455                 | 570  | 1055 | 880  | 480  | 260  |      |      |     | 320  | 120  |     |     |                    |                  |     |     |     |     |     |     |
|               | 4              | 7,5   |        |          |      |                     | 615  | 1100 | 925  | 525  |      |      |      |     |      | 126  |     |     |                    |                  |     |     |     |     |     |     |
|               | 5              | 10    | 160 M2 |          |      | 601                 | 393  | 660  | 1145 | 970  | 570  |      |      |     | 315  | 372  |     |     |                    |                  | 140 |     |     |     |     |     |
|               | 6              | 15    |        |          |      |                     |      | 705  | 1195 | 1145 | 745  |      |      |     |      |      |     |     |                    |                  | 212 |     |     |     |     |     |
|               | 7              | 15    |        |          |      |                     |      | 750  | 1386 | 1190 | 790  |      |      |     |      |      |     |     |                    |                  | 220 |     |     |     |     |     |
|               | 8              | 15    |        |          |      |                     |      | 795  | 1431 | 1235 | 835  |      |      |     |      |      |     |     |                    |                  | 226 |     |     |     |     |     |
|               | 9              | 20    |        |          |      |                     |      | 840  | 1476 | 1280 | 880  |      |      |     |      |      |     |     |                    |                  | 244 |     |     |     |     |     |
|               | 10             | 20    |        |          |      |                     |      | 885  | 1521 | 1325 | 925  |      |      |     |      |      |     |     |                    |                  | 250 |     |     |     |     |     |
| KSP 40        | 2              | 7,5   |        | 132 S2   | 50   |                     |      | 40   | 532  | 455  | 410  | 1017 | 845  | 445 |      |      | 18  | 65  | 55                 | 260              | 320 | 185 | 160 | 30  | 110 | 130 |
|               | 2              | 10    |        |          |      |                     |      |      | 532  |      |      | 1223 | 1030 | 630 |      |      |     |     |                    | 30               | 110 |     |     |     |     | 135 |
|               | 3              | 15    | 160 M2 | 601      |      | 425                 | 587  |      | 1278 | 1085 | 685  | 315  | 372  | 215 |      |      |     |     |                    |                  |     |     |     |     |     |     |
|               | 4              | 20    |        |          |      |                     | 642  |      | 1377 | 1185 | 785  |      |      | 239 |      |      |     |     |                    |                  |     |     |     |     |     |     |
|               | 5              | 25    | 160 L2 | 645      |      | 465                 | 697  |      | 1446 | 1245 | 845  | 355  | 415  | 268 |      |      |     |     |                    |                  |     |     |     |     |     |     |
|               | 6              | 30    | 180 M2 |          |      |                     | 752  |      | 1506 | 1375 | 975  |      |      | 332 |      |      |     |     |                    |                  |     |     |     |     |     |     |
|               | 7              | 40    | 200 L2 | 747      |      | 485                 | 807  |      | 1649 | 1430 | 1030 | 400  | 460  | 405 |      |      |     |     |                    |                  |     |     |     |     |     |     |
|               | 8              | 40    |        |          |      |                     | 862  |      | 1709 | 1490 | 1090 |      |      | 418 |      |      |     |     |                    |                  |     |     |     |     |     |     |
|               | 9              | 50    | 225 M2 | 790      |      | 505                 | 917  |      | 1807 | 1575 | 1175 | 436  | 496  | 452 |      |      |     |     |                    |                  |     |     |     |     |     |     |
|               | 10             | 60    |        |          |      |                     | 972  |      | 1875 | 1665 | 1265 |      |      | 542 |      |      |     |     |                    |                  |     |     |     |     |     |     |
| KSP 50        | 2              | 15    | 160 M2 | 65       | 50   | 570                 | 752  | 430  | 1357 | 1030 | 630  | 18   | 80   | 62  | 315  | 375  | 190 | 160 | 35                 | 125              | 230 |     |     |     |     |     |
|               | 2              | 20    |        |          |      |                     |      |      | 632  | 1364 | 1135 |      |      |     | 735  | 35   |     |     |                    |                  | 125 | 242 |     |     |     |     |
|               | 3              | 25    | 160 L2 |          |      | 697                 | 470  | 632  | 1481 | 1280 | 880  |      |      |     | 355  | 415  |     |     | 256                |                  |     |     |     |     |     |     |
|               | 3              | 30    | 180 M2 |          |      |                     |      | 752  | 1575 | 1210 | 810  |      |      |     |      |      |     |     | 280                |                  |     |     |     |     |     |     |
|               | 4              | 40    | 200 L2 |          |      | 747                 | 490  | 694  | 1653 | 1435 | 1035 |      |      |     | 400  | 460  |     |     | 396                |                  |     |     |     |     |     |     |
|               | 5              | 50    |        |          |      |                     |      | 756  | 1825 | 1495 | 1095 |      |      |     |      |      |     |     | 433                |                  |     |     |     |     |     |     |
|               | 6              | 60    | 225 M2 |          |      | 790                 | 515  | 818  | 1875 | 1575 | 1175 |      |      |     | 436  | 496  |     |     | 433                |                  |     |     |     |     |     |     |
|               | 7              | 60    |        |          |      |                     |      | 880  | 1925 | 1665 | 1265 |      |      |     |      |      |     |     | 542                |                  |     |     |     |     |     |     |
|               | 7              | 75    | 250 M2 |          |      | 900                 | 560  | 1830 | 1590 | 1190 | 120  |      |      |     | 485  | 545  |     |     | 635                |                  |     |     |     |     |     |     |
|               | KSP 65         | 2     | 30     |          |      | 160 L2              | 80   | 65   | 650  | 645  | 480  |      |      |     | 1335 | 1060 |     |     | 660                | 18               | 100 | 70  | 400 | 460 | 200 | 180 |
| 2             |                | 40    | 747    | 1437     | 1135 |                     |      |      |      | 735  |      | 40   | 140  | 405 |      |      |     |     |                    |                  |     |     |     |     |     |     |
| 3             |                | 50    | 200 L2 | 500      | 525  | 747                 |      |      | 1507 | 1210 | 810  | 440  | 500  | 428 |      |      |     |     |                    |                  |     |     |     |     |     |     |
| 3             |                | 50    |        |          |      | 720                 |      |      | 1670 | 1330 | 930  |      |      | 45  | 160  | 448  |     |     |                    |                  |     |     |     |     |     |     |
| 3             |                | 60    | 225 M2 | 570      | 620  | 790                 |      |      | 1740 | 1400 | 1000 | 485  | 545  | 524 |      |      |     |     |                    |                  |     |     |     |     |     |     |
| 4             |                | 75    | 900    |          |      | 1803                |      |      | 1460 | 1060 | 50   |      |      | 180 | 616  |      |     |     |                    |                  |     |     |     |     |     |     |
| 4             |                | 75    | 250 M2 | 790      | 620  | 958                 |      |      | 1925 | 1580 | 1180 | 560  | 620  | 638 |      |      |     |     |                    |                  |     |     |     |     |     |     |
| 5             |                | 100   |        |          |      | 860                 |      |      | 1925 | 1580 | 1180 |      |      | 55  | 180  | 806  |     |     |                    |                  |     |     |     |     |     |     |
| 5             |                | 125   | 280 M2 | 1010     | 687  | 2008                |      |      | 1485 | 1085 | 225  | 930  |      |     |      |      |     |     |                    |                  |     |     |     |     |     |     |
| KSP 80        |                | 2     | 60     | 225 M2   | 100  | 80                  |      |      | 750  | 790  | 592  | 1585 | 1205 | 805 | 20   | 100  | 83  | 440 | 500                |                  |     |     | 267 | 180 |     |     |
|               | 2              | 75    | 250 M2 | 900      |      |                     | 637  | 1700 |      | 1295 |      | 895  | 45   | 160 |      |      |     | 622 |                    |                  |     |     |     |     |     |     |
|               | 3              | 100   | 280 S2 | 958      |      |                     | 687  | 958  | 1846 | 1440 | 1040 | 560  | 620  | 822 |      |      |     |     |                    |                  |     |     |     |     |     |     |
|               | 3              | 125   |        |          |      |                     |      | 943  | 2008 | 1485 | 1085 |      |      | 55  |      | 180  | 873 |     |                    |                  |     |     |     |     |     |     |
|               | 4              | 125   | 280 M2 | 1026     |      |                     | 1010 | 2979 | 1570 | 1170 | 225  | 900  |      |     |      |      |     |     |                    |                  |     |     |     |     |     |     |

**KSP SERİSİ ELEKTRİK MOTORLU POMPA BOYUTLARI**

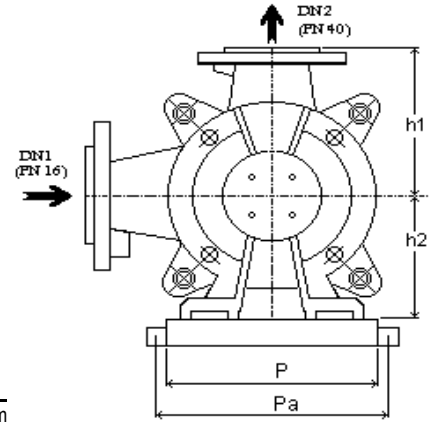
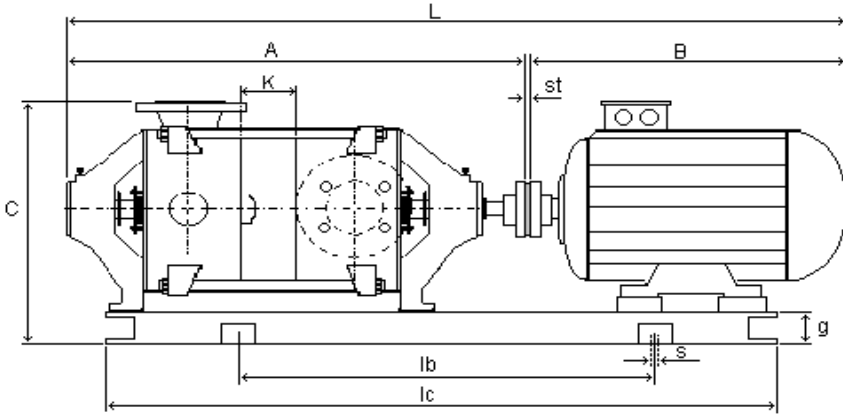

**1450 D/D**

| POMPA TİPİ | Kad. sayısı | MOTOR |        | FLANŞLAR |      | BOYUT ÖLÇÜLERİ (m) |      |      |       |      |     |      |      |     |     |     |     |     |     | AĞIRLIK (Kg.) |          |
|------------|-------------|-------|--------|----------|------|--------------------|------|------|-------|------|-----|------|------|-----|-----|-----|-----|-----|-----|---------------|----------|
|            |             | HP    | Gövde  | DN1      | DN2  | A                  | B    | C    | L     | lc   | lb  | s    | g    | K   | P   | Pa  | h1  | h2  | st  |               | ÖLÇ. (φ) |
| KSP 32     | 2           | 0,75  | 80     | 50       | 32   | 525                | 278  | 350  | 828   | 705  | 305 | 18   | 65   | 45  | 190 | 250 | 153 | 132 | 25  | 80            | 83       |
|            | 3           | 1     |        |          |      | 570                |      |      | 873   | 750  | 350 |      |      |     |     |     |     |     |     |               | 95       |
|            | 4           | 1     |        |          |      | 615                |      |      | 918   | 795  | 395 |      |      |     |     |     |     |     |     |               | 100      |
|            | 5           | 1,5   |        |          |      | 660                |      |      | 993   | 860  | 460 |      |      |     |     |     |     |     |     |               | 108      |
|            | 6           | 1,5   | 90 S4  |          |      | 308                | 705  |      | 1038  | 905  | 505 |      |      |     |     |     |     |     | 115 |               |          |
|            | 7           | 2     |        |          |      |                    | 750  |      | 1155  | 975  | 575 |      |      |     |     |     |     |     | 123 |               |          |
|            | 8           | 2     |        |          |      |                    | 795  |      | 1200  | 1020 | 620 |      |      |     |     |     |     |     | 130 |               |          |
|            | 9           | 3     |        |          |      |                    | 840  |      | 1245  | 1065 | 665 |      |      |     |     |     |     |     | 140 |               |          |
|            | 10          | 3     |        |          |      |                    | 885  |      | 1290  | 1110 | 710 |      |      |     |     |     |     |     | 148 |               |          |
|            | KSP 40      | 2     |        |          |      |                    | 1,5  |      | 90 S4 | 50   | 40  |      |      |     |     |     |     |     | 532 | 308           | 410      |
| 3          |             | 2     | 90 L4  | 587      | 333  | 955                | 820  | 420  | 120   |      |     |      |      |     |     |     |     |     |     |               |          |
| 4          |             | 3     | 100 L4 | 642      | 375  | 1079               | 890  | 490  | 137   |      |     |      |      |     |     |     |     |     |     |               |          |
| 5          |             | 4     |        | 697      |      | 1102               | 965  | 565  | 154   |      |     |      |      |     |     |     |     |     |     |               |          |
| 6          |             | 4     | 112 M4 | 752      | 394  | 1157               | 1020 | 620  | 170   |      |     |      |      |     |     |     |     |     |     |               |          |
| 7          |             | 5,5   |        | 807      |      | 1231               | 1080 | 680  | 188   |      |     |      |      |     |     |     |     |     |     |               |          |
| 8          |             | 5,5   | 132 S4 | 862      | 455  | 1286               | 1135 | 735  | 200   |      |     |      |      |     |     |     |     |     |     |               |          |
| 9          |             | 7,5   |        | 917      |      | 1402               | 1230 | 830  | 230   |      |     |      |      |     |     |     |     |     |     |               |          |
| 10         |             | 7,5   | 972    | 1457     | 1285 | 885                | 243  |      |       |      |     |      |      |     |     |     |     |     |     |               |          |
| KSP 50     |             | 2     | 3      | 100 L4   | 65   | 50                 | 570  | 375  | 415   |      |     | 975  | 855  | 455 | 18  | 65  | 62  | 260 | 320 | 190           |          |
|            | 3           | 4     | 632    |          |      |                    | 1037 |      |       | 915  | 515 | 158  |      |     |     |     |     |     |     |               |          |
|            | 4           | 5,5   | 112 M4 | 694      |      |                    | 985  | 585  |       | 182  |     |      |      |     |     |     |     |     |     |               |          |
|            | 5           | 7,5   | 132 S4 | 756      |      |                    | 1090 | 690  |       | 207  |     |      |      |     |     |     |     |     |     |               |          |
|            | 6           | 7,5   |        | 818      |      |                    | 1303 | 1150 | 750   | 228  |     |      |      |     |     |     |     |     |     |               |          |
|            | 7           | 10    | 132 M4 | 880      |      |                    | 1403 | 1250 | 850   | 248  |     |      |      |     |     |     |     |     |     |               |          |
|            | 8           | 10    |        | 942      |      |                    | 1465 | 1310 | 910   | 264  |     |      |      |     |     |     |     |     |     |               |          |
|            | 9           | 15    | 160 M4 | 1004     |      |                    | 1640 | 1465 | 1065  | 340  |     |      |      |     |     |     |     |     |     |               |          |
|            | 10          | 15    |        | 1066     |      |                    | 1702 | 1525 | 1125  | 375  |     |      |      |     |     |     |     |     |     |               |          |
|            | KSP 65      | 2     | 5,5    | 112 M4   |      |                    | 80   | 65   | 650   | 394  | 430 | 1074 | 840  | 440 |     | 18  |     |     |     |               | 80       |
| 3          |             | 7,5   | 132 S4 | 720      | 455  | 1205               |      |      | 950   | 550  |     | 228  |      |     |     |     |     |     |     |               |          |
| 4          |             | 10    | 132 M4 | 790      | 493  | 1313               |      |      | 1060  | 660  |     | 256  |      |     |     |     |     |     |     |               |          |
| 5          |             | 15    | 160 M4 | 860      | 601  | 1296               |      |      | 1220  | 820  |     | 340  |      |     |     |     |     |     |     |               |          |
| 6          |             | 20    | 160 L4 | 930      | 645  | 1610               |      |      | 1335  | 935  | 394 |      |      |     |     |     |     |     |     |               |          |
| 7          |             | 20    |        | 1000     |      | 1680               |      |      | 1405  | 1005 | 415 |      |      |     |     |     |     |     |     |               |          |
| 8          |             | 25    | 180 M4 | 1070     | 659  | 1764               |      |      | 1475  | 1075 | 462 |      |      |     |     |     |     |     |     |               |          |
| 9          |             | 25    |        | 1140     |      | 1834               |      |      | 1545  | 1145 | 482 |      |      |     |     |     |     |     |     |               |          |
| 10         |             | 30    | 180 L4 | 1210     | 697  | 1947               |      |      | 1670  | 1270 | 545 |      |      |     |     |     |     |     |     |               |          |
| KSP 80     |             | 2     | 15     | 160 M4   | 100  | 80                 |      |      | 750   | 601  | 547 | 1386 | 1045 | 645 | 20  |     | 100 | 83  | 415 | 475           | 267      |
|            | 3           | 20    | 160 L4 | 833      |      |                    | 645  | 1513 | 1175  | 775  |     | 376  |      |     |     |     |     |     |     |               |          |
|            | 4           | 25    | 180 M4 | 916      |      |                    | 659  | 1610 | 1255  | 855  |     | 428  |      |     |     |     |     |     |     |               |          |
|            | 5           | 30    | 180 L4 | 999      |      |                    | 697  | 1736 | 1380  | 980  |     | 484  |      |     |     |     |     |     |     |               |          |
|            | 6           | 30    |        | 1082     |      |                    |      | 1819 | 1465  | 1065 | 514 |      |      |     |     |     |     |     |     |               |          |
|            | 7           | 40    | 200 L4 | 1165     |      |                    | 747  | 1952 | 1585  | 1185 | 600 |      |      |     |     |     |     |     |     |               |          |
|            | 8           | 50    | 225 S4 | 1248     |      |                    | 795  | 2088 | 1705  | 1305 | 680 |      |      |     |     |     |     |     |     |               |          |
|            | 9           | 50    |        | 1331     |      |                    |      | 2171 | 1790  | 1390 | 720 |      |      |     |     |     |     |     |     |               |          |
|            | 10          | 60    | 225 M4 | 1414     |      |                    | 820  | 2279 | 1895  | 1495 | 780 |      |      |     |     |     |     |     |     |               |          |

**KSP SERİSİ ELEKTRİK MOTORLU POMPA BOYUTLARI**

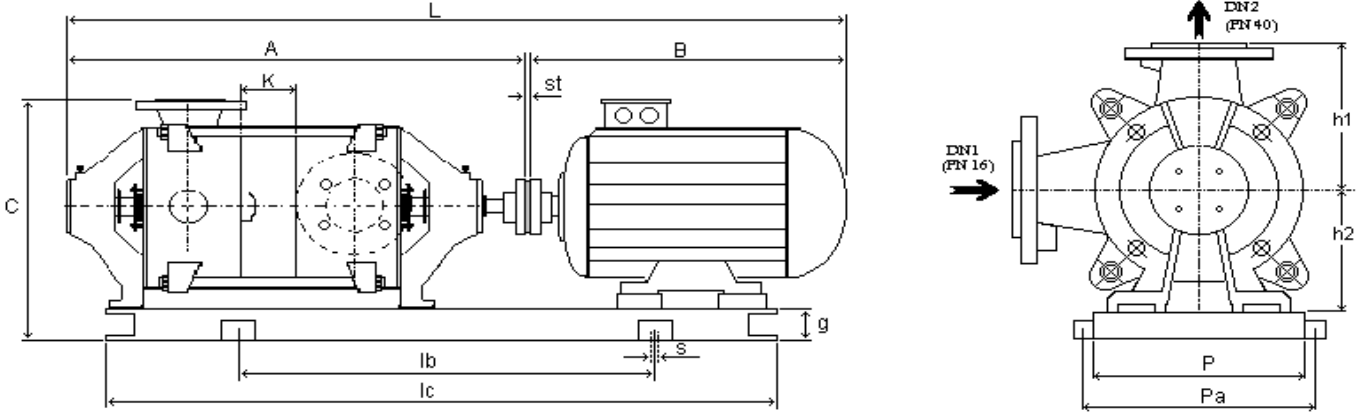

**1450 D/D**

| POMPA TİPİ | Kad. sayısı | MOTOR |        | FLANŞLAR |      | BOYUT ÖLÇÜLERİ (mm) |      |      |      |      |      |      |      |      |      |      |     |     | KAPLIN ÖLÇ. (φ) | AĞIRLIK (Kg.) |     |     |      |      |
|------------|-------------|-------|--------|----------|------|---------------------|------|------|------|------|------|------|------|------|------|------|-----|-----|-----------------|---------------|-----|-----|------|------|
|            |             | HP    | Gövde  | DN1      | DN2  | A                   | B    | C    | L    | lc   | lb   | s    | g    | K    | P    | Pa   | h1  | h2  |                 |               | st  |     |      |      |
| KSP 100    | 2           | 30    | 180 L4 | 125      | 100  | 866                 | 697  | 650  | 1603 | 1240 | 840  | 22   | 100  | 100  | 440  | 500  | 300 | 250 | 40              | 140           | 505 |     |      |      |
|            | 2           | 40    | 200 L4 |          |      | 966                 | 747  |      | 1753 | 1280 | 880  |      |      |      |      |      |     |     |                 |               |     |     |      |      |
|            | 3           | 50    | 225 S4 |          |      | 1066                | 795  |      | 1906 | 1415 | 1015 |      |      |      |      |      |     |     |                 |               |     | 55  | 200  | 1120 |
|            | 4           | 60    | 225 M4 |          |      | 1166                | 820  |      | 2031 | 1540 | 1140 |      |      |      |      |      |     |     |                 |               |     |     |      |      |
|            | 5           | 75    | 250 M4 |          |      | 1266                | 900  | 670  | 2216 | 1700 | 1300 |      | 120  |      | 878  |      |     |     |                 |               |     |     |      |      |
|            | 6           | 75    |        |          |      | 1366                |      | 2316 | 1800 | 1400 | 140  |      |      |      |      | 660  |     |     | 620             | 55            |     | 225 | 1250 |      |
|            | 7           | 100   | 280 S4 |          |      | 1466                | 958  | 720  | 2479 | 1955 |      |      | 1555 |      |      |      |     |     |                 |               |     |     |      |      |
|            | 8           | 125   | 280 M4 |          |      | 1566                | 1010 | 2631 | 2110 | 1710 |      |      |      |      |      |      |     |     |                 |               |     |     |      |      |
| KSP 125    | 2           | 60    | 225 M4 | 150      | 125  | 965                 | 820  | 815  | 1830 | 1415 | 1015 | 25   | 140  | 115  | 550  | 610  | 375 | 300 | 45              | 160           | 815 |     |      |      |
|            |             | 75    | 250 M4 |          |      | 1080                | 900  |      | 2030 | 1500 | 1100 |      |      |      |      |      |     |     |                 |               |     | 55  | 200  | 1106 |
|            | 3           | 100   | 280 S4 |          |      | 1195                | 958  |      | 2208 | 1680 | 1280 |      |      |      |      |      |     |     |                 |               |     |     |      |      |
|            |             | 125   | 280 M4 |          |      | 1310                | 1010 |      | 2375 | 1725 | 1325 |      |      |      |      |      |     |     |                 |               |     | 160 | 630  | 690  |
|            | 4           | 150   | 315 S4 |          |      | 1425                | 1098 | 850  | 2583 | 1895 | 1495 |      |      |      |      |      |     |     |                 |               |     |     |      |      |
|            | 5           | 180   | 315 M4 |          |      | 1540                | 1150 | 2750 | 2060 | 1660 |      |      |      |      |      |      |     |     |                 |               |     |     |      |      |
|            | 6           | 220   |        |          |      | 1655                |      | 2865 | 2175 | 1775 |      |      |      |      |      |      |     |     |                 |               |     |     |      |      |
|            | KSP 150     | 2     | 100    |          |      | 280 S4              | 200  | 150  | 1170 | 958  | 940  |      | 2183 |      | 1620 | 1220 |     |     | 25              | 160           |     | 145 | 650  | 710  |
| 125        |             |       | 280 M4 | 2235     | 1670 | 1270                |      |      |      | 60   |      | 250  | 1780 |      |      |      |     |     |                 |               |     |     |      |      |
| 150        |             |       | 315 S4 | 2328     | 1720 | 1320                |      |      |      |      |      |      |      |      |      |      |     |     |                 |               |     |     |      |      |
| 180        |             |       | 315 M4 | 2525     | 1920 | 1520                |      |      |      |      |      |      |      |      |      |      |     |     |                 |               |     |     |      |      |
| 220        |             | 2740  |        | 2120     | 1720 | 2030                |      |      |      |      |      |      |      |      |      |      |     |     |                 |               |     |     |      |      |
| 3          |             | 180   | 315 M4 | 1315     | 1150 | 2525                |      |      | 1920 | 1520 | 2740 | 2120 | 1720 | 2030 |      |      |     |     |                 |               |     |     |      |      |
|            |             |       |        | 220      |      |                     |      |      |      |      |      |      |      |      | 2260 |      |     |     |                 |               |     |     |      |      |
| 4          |             | 250   | 315 L4 | 1460     | 1220 | 2740                |      |      | 2120 | 1720 | 2030 | 2260 |      |      |      |      |     |     |                 |               |     |     |      |      |