

# KSP 50

- KSP 50-1
- KSP 50-2
- KSP 50-3
- KSP 50-4
- KSP 50-5
- KSP 50-6
- KSP 50-7
- KSP 50-8
- KSP 50-9
- KSP 50-10

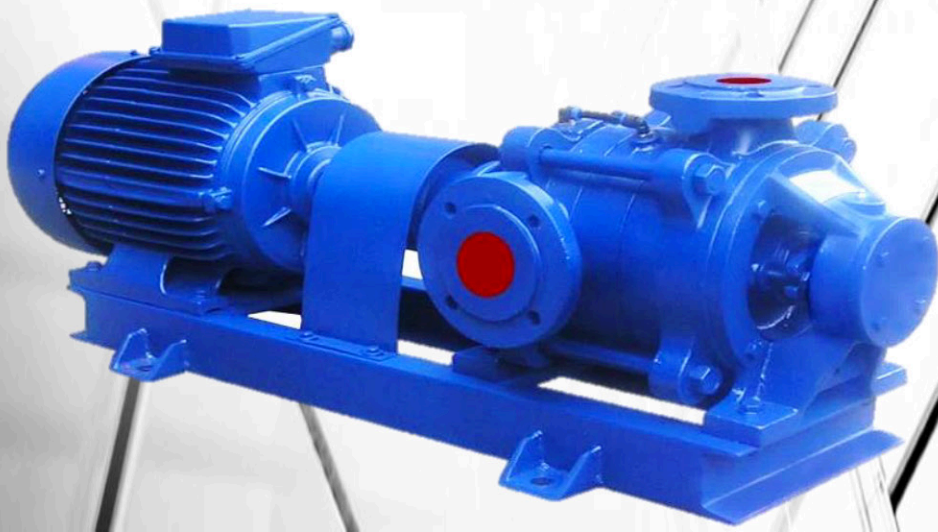

## KSP 50-10

### Pompa Bilgileri

Pompa Tipi	KSP 50-10	Sızdırmazlık	Yumuşak Salmastra
Çark Çapı (mm) $\phi$	165-175	Yoğunluk (kg/m <sup>3</sup> )	1
Sıvı Cinsi	Su	Sıcaklık	-1°C-+110

### Motor Bilgileri

Güç (HP)	15
Voltaj (Volt)	380
Faz	3
Frekans (Hz)	50-60
Devir (rpm) (d/dk)	1500

$\phi 165$		$\phi 175$	
Q (m <sup>3</sup> /h)	Hm (m)	Q (m <sup>3</sup> /h)	Hm (m)
3	99	3	116
6	98	6	115
9	95	9	112
12	92	12	109
15	87	15	105
18	81	18	100
21	75	21	93
24	67	24	86
		27	77

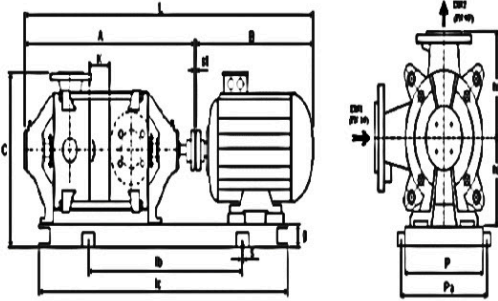

### KSP 50-10

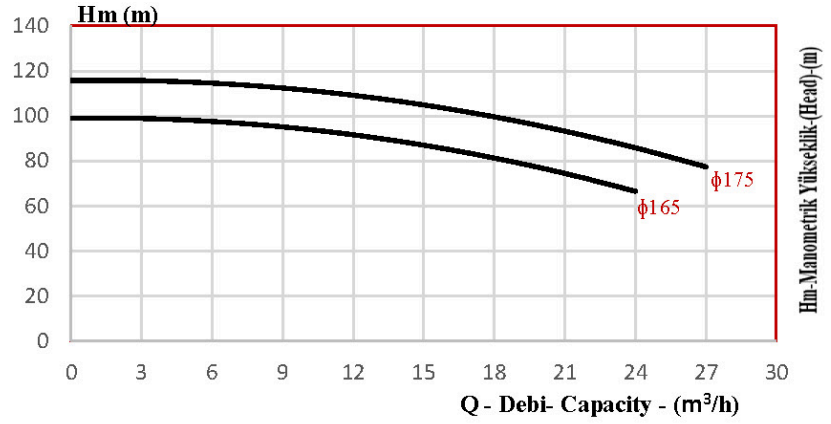

### KSP 50-10

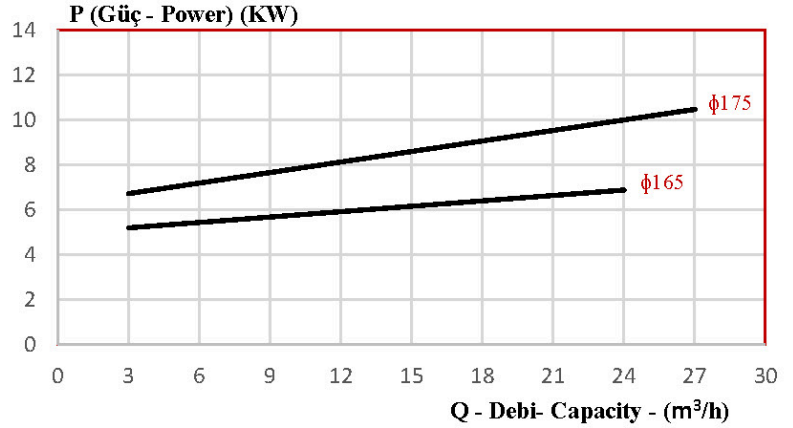

### KSP 50-10

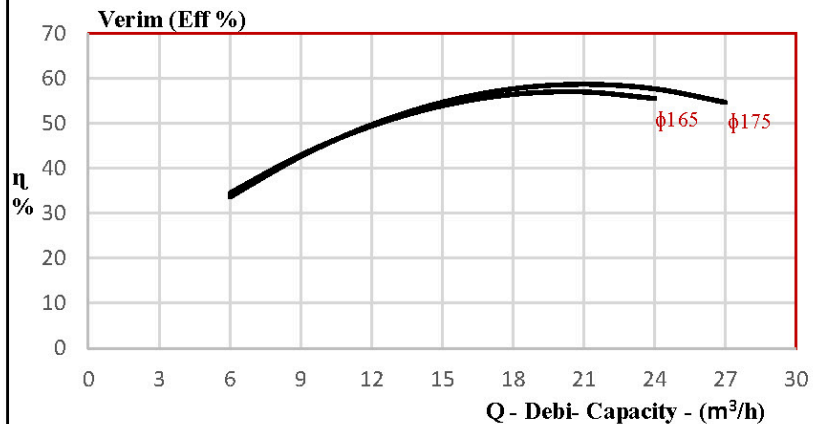

Pompa Tipi	KSP 50-10	
Kademe Sayısı	10	
Motor	HP	15
	Gövde	160 M4
Flanşlar	DN1 (Emme) (mm)	65
	DN2 (Basma) (mm)	50
Boyut Ölçüsü (mm)	A	1066
	B	601
	C	430
	L	1702
	lc	1525
	lb	1125
	K	62
	P	312
	Pa	372
	h1	190
h2	160	
Kaplin Ölçüsü ( $\phi$ ) (mm)	125	
Ağırlık (kg)	375	

## KSP 50-9

### Pompa Bilgileri

Pompa Tipi	KSP 50-9	Sızdırmazlık	Yumuşak Salmastra
Çark Çapı (mm) $\phi$	165-175	Yoğunluk (kg/m <sup>3</sup> )	1
Sıvı Cinsi	Su	Sıcaklık	-1°C- +110

### Motor Bilgileri

Güç (HP)	15
Voltaj (Volt)	380
Faz	3
Frekans (Hz)	50-60
Devir (rpm) (d/dk)	1500

$\phi$ 165		$\phi$ 175	
Q (m <sup>3</sup> /h)	Hm (m)	Q (m <sup>3</sup> /h)	Hm (m)
3	89	3	104
6	88	6	103
9	86	9	101
12	82	12	98
15	78	15	94
18	73	18	90
21	67	21	84
24	60	24	77
		27	70

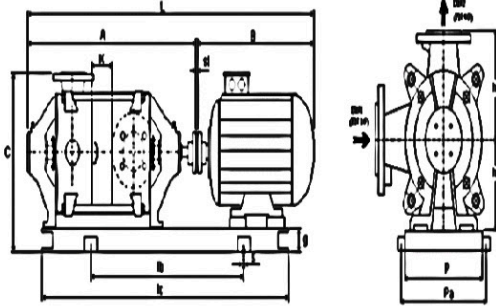

Pompa Tipi	KSP 50-9	
Kademe Sayısı	9	
Motor	HP	15
	Gövde	160 M4
Flanşlar	DN1 (Emme) (mm)	65
	DN2 (Basma) (mm)	50
Boyut Ölçüsü (mm)	A	1004
	B	601
	C	430
	L	1640
	lc	1465
	lb	1065
	K	62
	P	312
	Pa	372
h1	190	
h2	160	
Kaplin Ölçüsü ( $\phi$ ) (mm)	125	
Ağırlık (kg)	340	

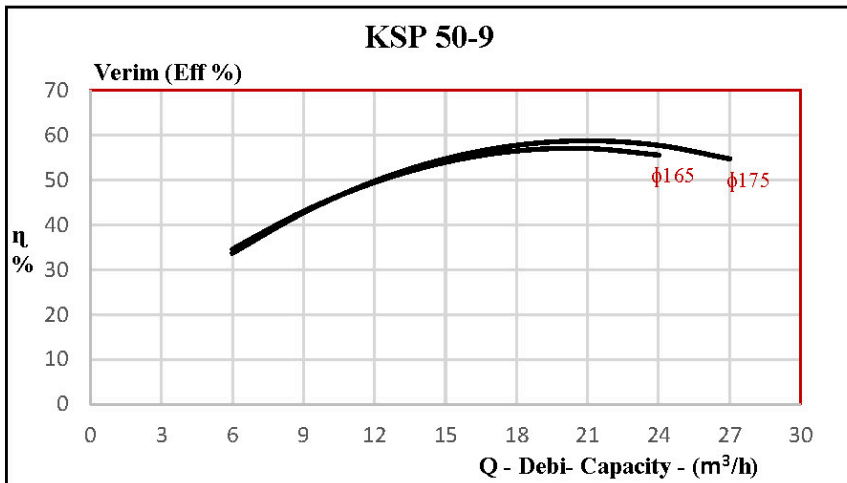
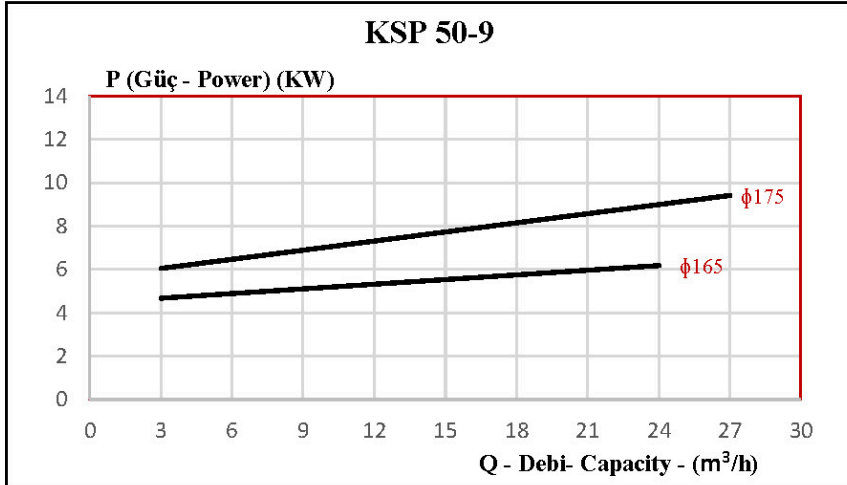
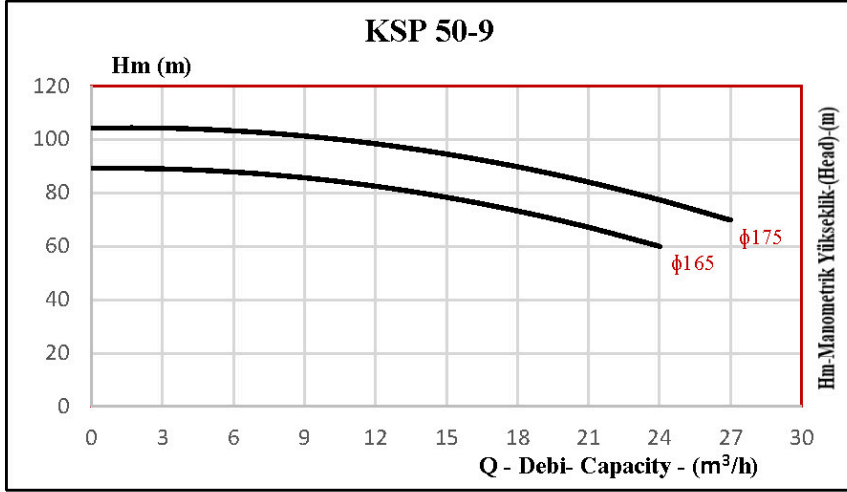

## KSP 50-8

### Pompa Bilgileri

Pompa Tipi	KSP 50-8	Sızdırmazlık	Yumuşak Salmastra
Çark Çapı (mm) $\phi$	165-175	Yoğunluk (kg/m <sup>3</sup> )	1
Sıvı Cinsi	Su	Sıcaklık	-1°C- +110

### Motor Bilgileri

Güç (HP)	10
Voltaj (Volt)	380
Faz	3
Frekans (Hz)	50-60
Devir (rpm) (d/dk)	1500

$\phi 165$		$\phi 175$	
Q (m <sup>3</sup> /h)	Hm (m)	Q (m <sup>3</sup> /h)	Hm (m)
3	79	3	93
6	78	6	92
9	76	9	90
12	73	12	87
15	70	15	84
18	65	18	80
21	60	21	75
24	53	24	69
		27	62

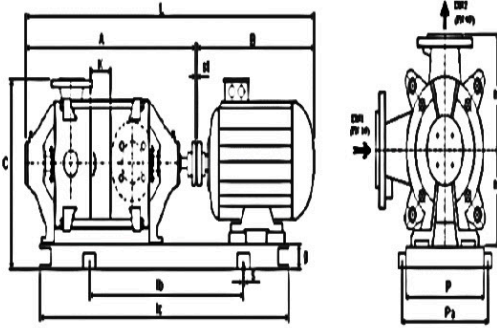

Pompa Tipi	KSP 50-8	
Kademe Sayısı	8	
Motor	HP	10
	Gövde	132 M4
Flanşlar	DN1 (Emme) (mm)	65
	DN2 (Basma) (mm)	50
Boyut Ölçüsü (mm)	A	942
	B	493
	C	430
	L	1465
	lc	1310
	lb	910
	K	62
	P	260
	Pa	320
	h1	190
h2	160	
Kaplin Ölçüsü ( $\phi$ ) (mm)	110	
Ağırlık (kg)	264	

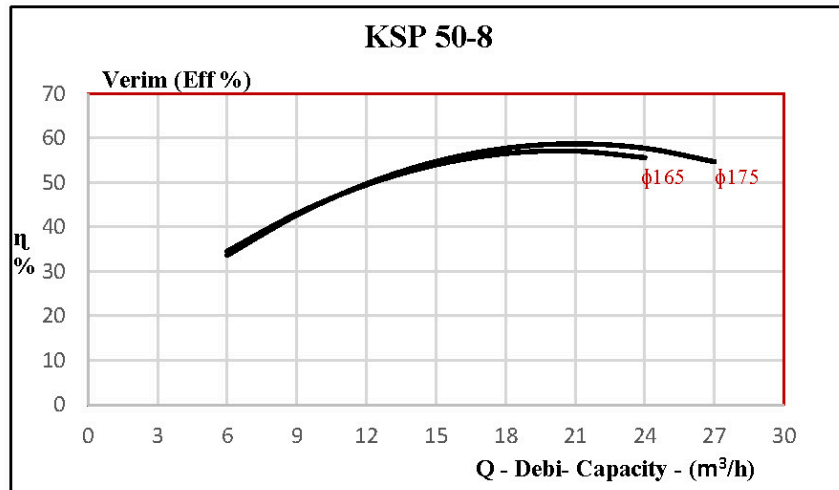
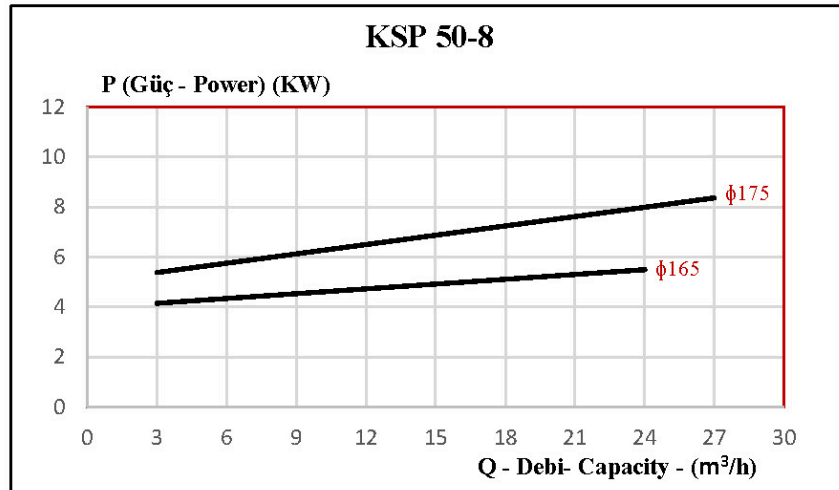
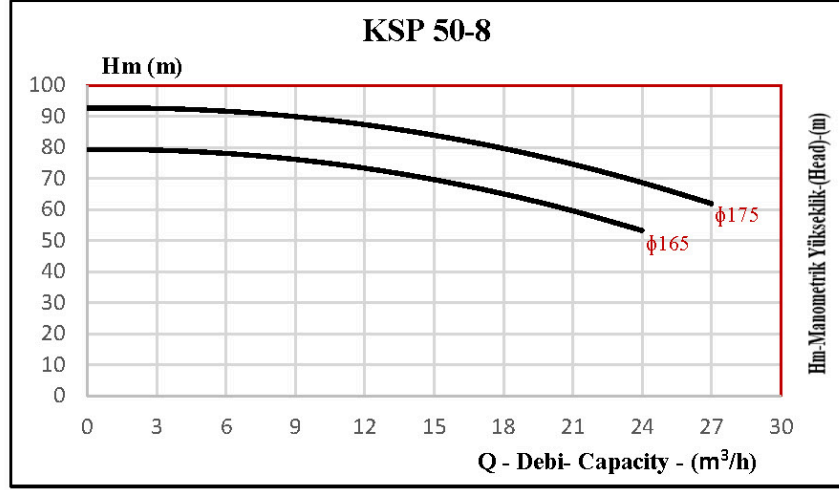

## KSP 50-7

### Pompa Bilgileri

Pompa Tipi	KSP 50-7	Sızdırmazlık	Yumuşak Salmastra
Çark Çapı (mm) $\phi$	165-175	Yoğunluk (kg/m <sup>3</sup> )	1
Sıvı Cinsi	Su	Sıcaklık	-1°C- +110

### Motor Bilgileri

Güç (HP)	10
Voltaj (Volt)	380
Faz	3
Frekans (Hz)	50-60
Devir (rpm) (d/dk)	1500

### $\phi$ 165

### $\phi$ 175

Q (m <sup>3</sup> /h)	Hm (m)	Q (m <sup>3</sup> /h)	Hm (m)
3	69	3	81
6	68	6	80
9	67	9	79
12	64	12	76
15	61	15	73
18	57	18	70
21	52	21	65
24	47	24	60
		27	54

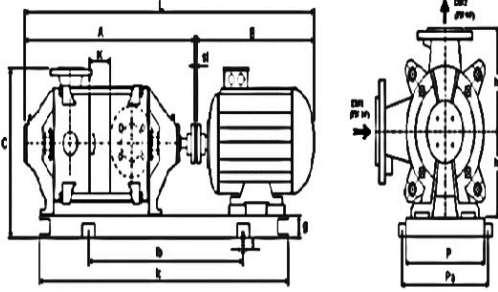

### KSP 50-7

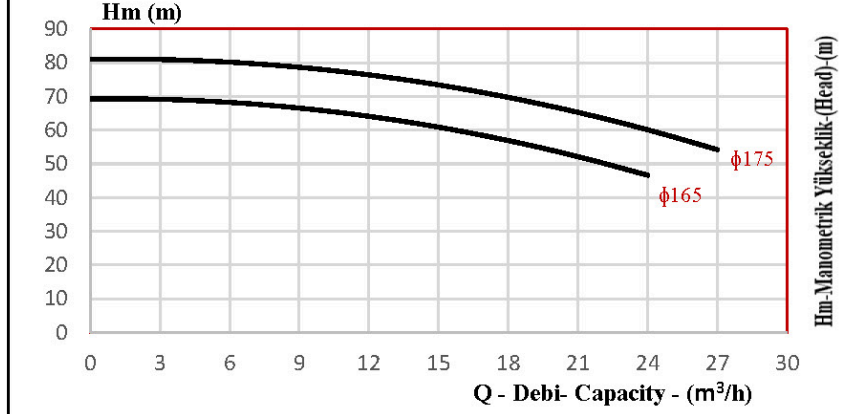

### KSP 50-7

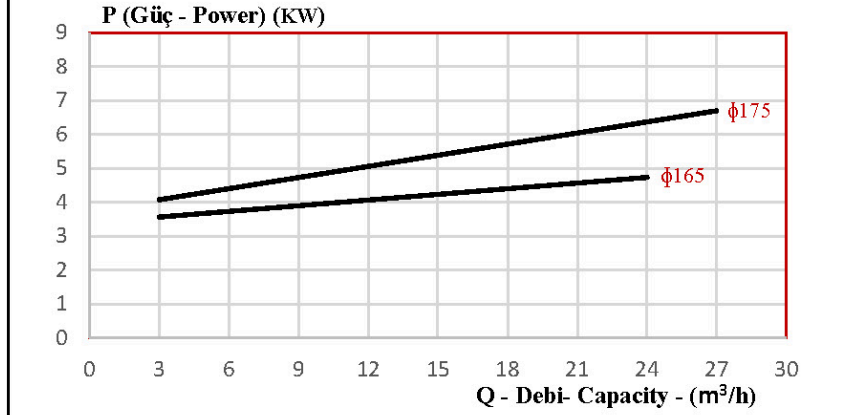

### KSP 50-7

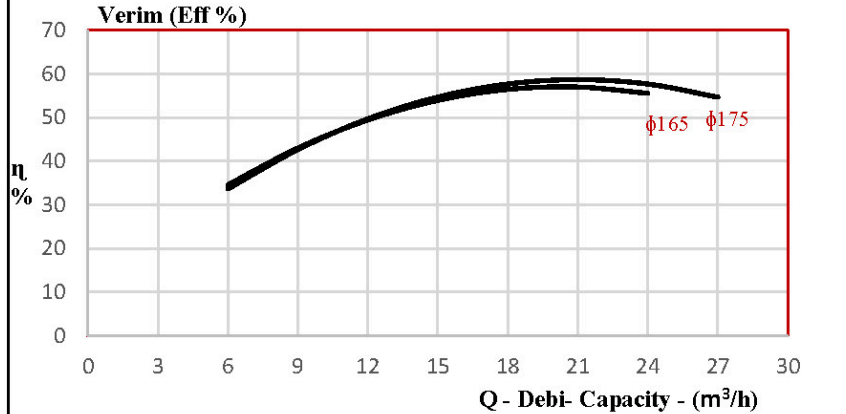

Pompa Tipi	KSP 50-7	
Kademe Sayısı	7	
Motor	HP	10
	Gövde	132 M4
Flanşlar	DN1 (Emme) (mm)	65
	DN2 (Basma) (mm)	50
Boyut Ölçüsü (mm)	A	880
	B	493
	C	430
	L	1403
	lc	1250
	lb	850
	K	62
	P	260
	Pa	320
h1	190	
h2	160	
Kaplin Ölçüsü ( $\phi$ ) (mm)	110	
Ağırlık (kg)	248	

## KSP 50-6

### Pompa Bilgileri

Pompa Tipi	KSP 50-6	Sızdırmazlık	Yumuşak Salmastra
Çark Çapı (mm) $\phi$	165-175	Yoğunluk (kg/m <sup>3</sup> )	1
Sıvı Cinsi	Su	Sıcaklık	-1°C- +110

### Motor Bilgileri

Güç (HP)	7,5
Voltaj (Volt)	380
Faz	3
Frekans (Hz)	50-60
Devir (rpm) (d/dk)	1500

### $\phi$ 165

### $\phi$ 175

Q (m <sup>3</sup> /h)	Hm (m)	Q (m <sup>3</sup> /h)	Hm (m)
3	59	3	69
6	59	6	69
9	57	9	67
12	55	12	66
15	52	15	63
18	49	18	60
21	45	21	56
24	40	24	52
		27	46

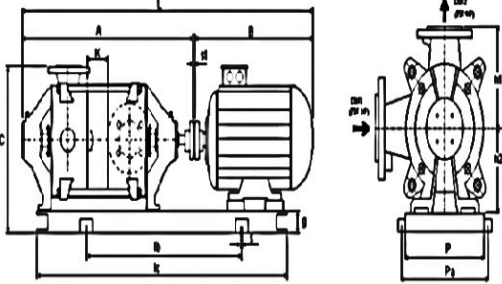

### KSP 50-6

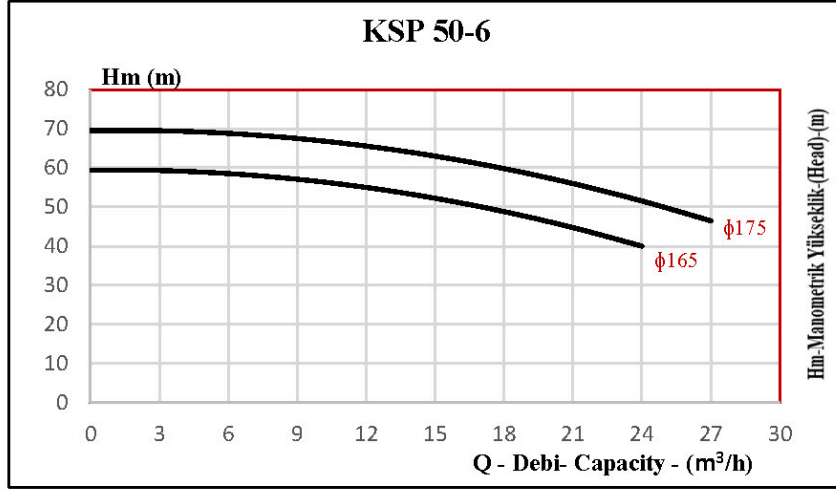

### KSP 50-6

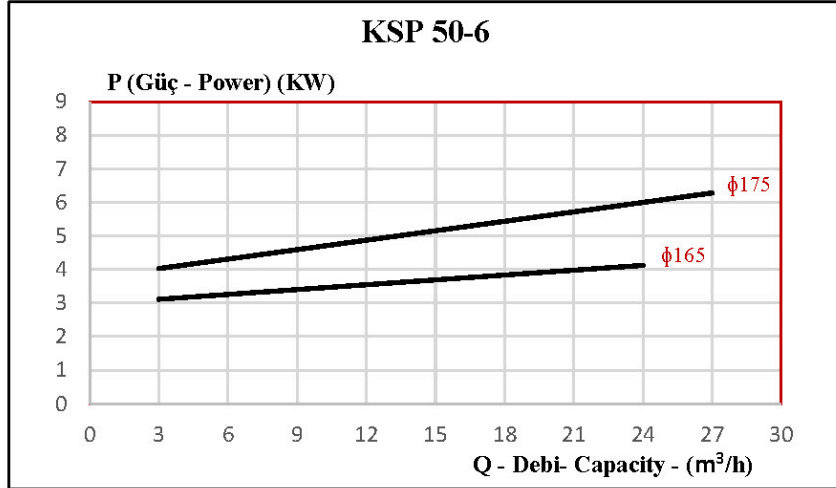

### KSP 50-6

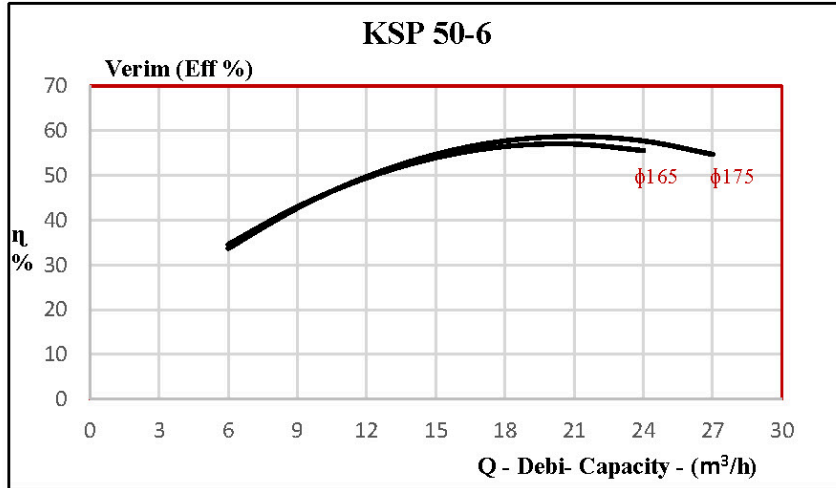

Pompa Tipi	KSP 50-6	
Kademe Sayısı	6	
Motor	HP	7,5
	Gövde	132 S4
Flanşlar	DN1 (Emme) (mm)	65
	DN2 (Basma) (mm)	50
Boyut Ölçüsü (mm)	A	818
	B	455
	C	430
	L	1303
	lc	1150
	lb	750
	K	62
	P	260
	Pa	320
	h1	190
h2	160	
Kaplin Ölçüsü ( $\phi$ ) (mm)	110	
Ağırlık (kg)	228	

## KSP 50-5

### Pompa Bilgileri

Pompa Tipi	KSP 50-5	Sızdırmazlık	Yumuşak Salmastra
Çark Çapı (mm) $\phi$	165-175	Yoğunluk (kg/m <sup>3</sup> )	1
Sıvı Cinsi	Su	Sıcaklık	-1°C- +110

### Motor Bilgileri

Güç (HP)	7,5
Voltaj (Volt)	380
Faz	3
Frekans (Hz)	50-60
Devir (rpm) (d/dk)	1500

$\phi$ 165		$\phi$ 175	
Q (m <sup>3</sup> /h)	Hm (m)	Q (m <sup>3</sup> /h)	Hm (m)
3	49	3	58
6	49	6	57
9	48	9	56
12	46	12	55
15	44	15	52
18	41	18	50
21	37	21	47
24	33	24	43
		27	39

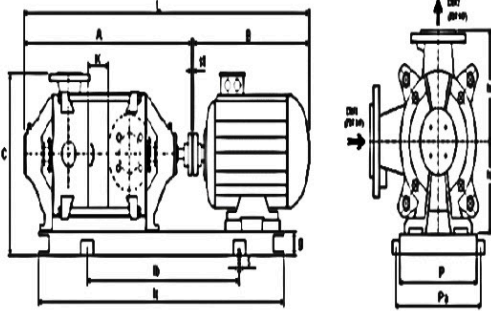

Pompa Tipi	KSP 50-5	
Kademe Sayısı	5	
Motor	HP	7,5
	Gövde	132 S4
Flanşlar	DN1 (Emme) (mm)	65
	DN2 (Basma) (mm)	50
Boyut Ölçüsü (mm)	A	756
	B	455
	C	415
	L	1241
	lc	1090
	lb	690
	K	62
	P	260
	Pa	320
	h1	190
h2	160	
Kaplin Ölçüsü ( $\phi$ ) (mm)	110	
Ağırlık (kg)	207	

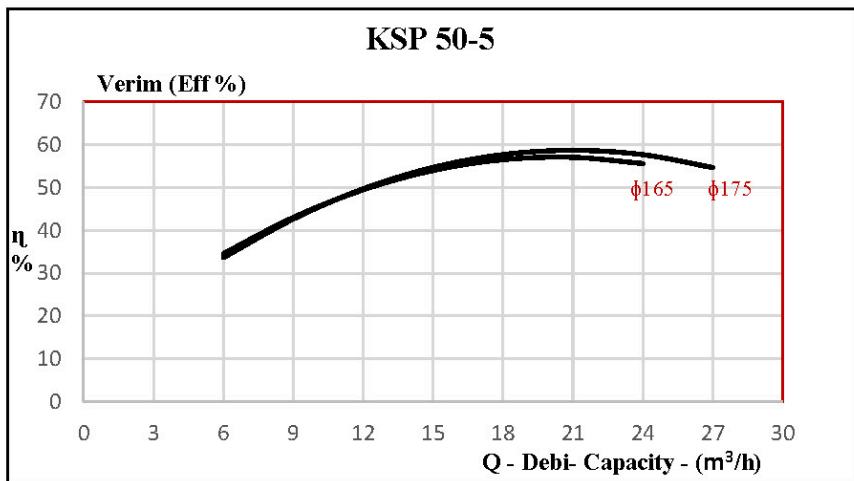
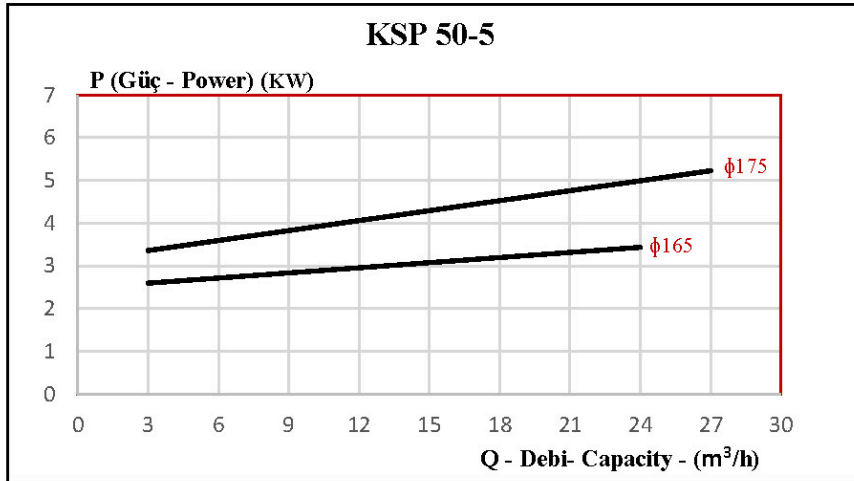
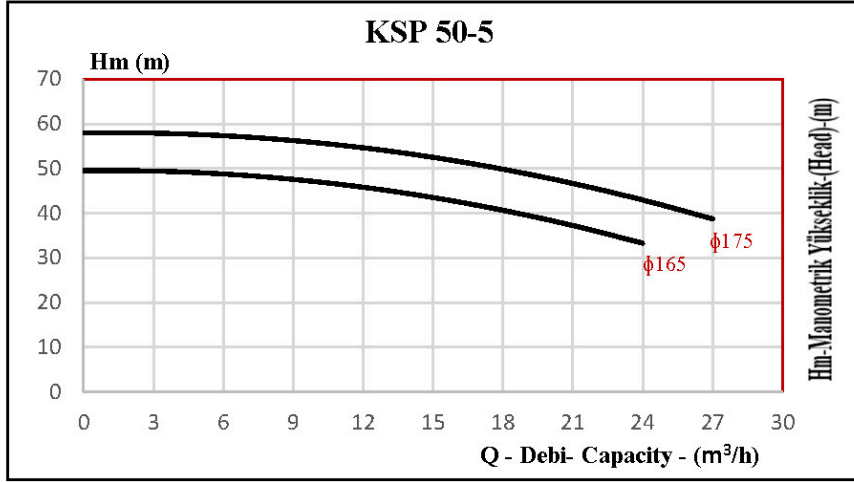

## KSP 50-4

### Pompa Bilgileri

Pompa Tipi	KSP 50-4	Sızdırmazlık	Yumuşak Salmastra
Çark Çapı (mm) $\phi$	165-175	Yoğunluk (kg/m <sup>3</sup> )	1
Sıvı Cinsi	Su	Sıcaklık	-1°C-+110

### Motor Bilgileri

Güç (HP)	5,5
Voltaj (Volt)	380
Faz	3
Frekans (Hz)	50-60
Devir (rpm) (d/dk)	1500

### $\phi$ 165

### $\phi$ 175

Q (m <sup>3</sup> /h)	Hm (m)	Q (m <sup>3</sup> /h)	Hm (m)
3	40	3	46
6	39	6	46
9	38	9	45
12	37	12	44
15	35	15	42
18	33	18	40
21	30	21	37
24	27	24	34
		27	31

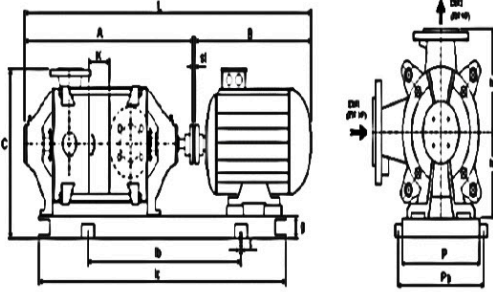

### KSP 50-4

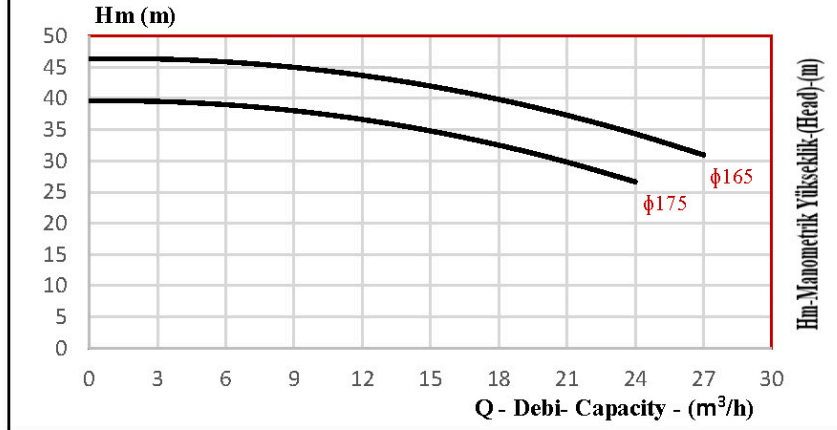

### KSP 50-4

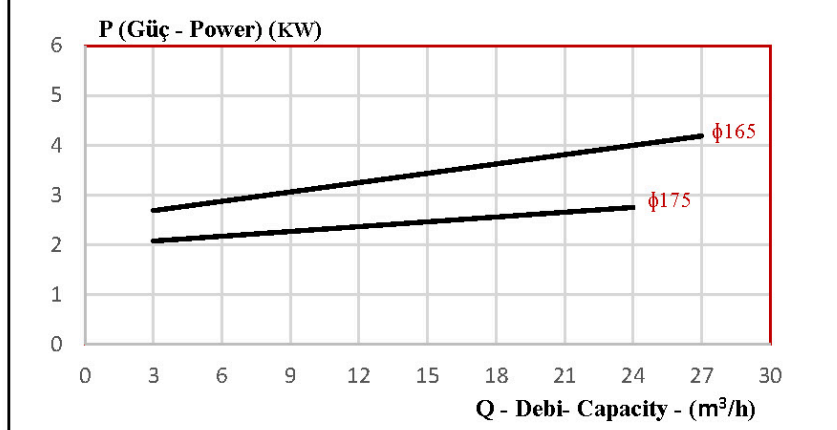

### KSP 50-4

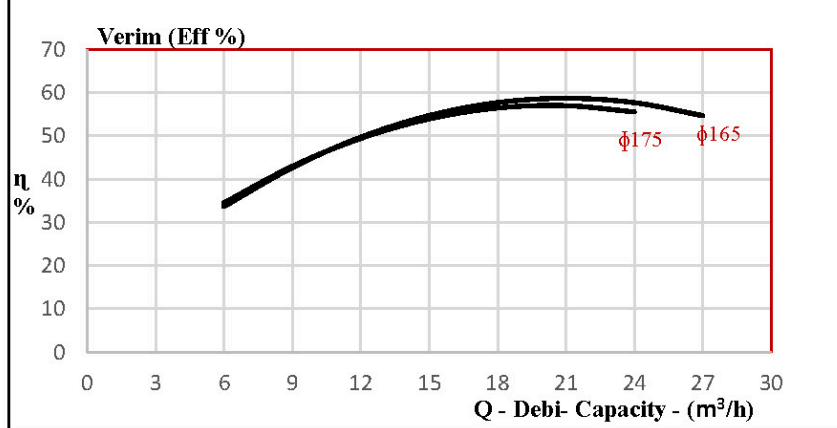

Pompa Tipi	KSP 50-4	
Kademe Sayısı	4	
Motor	HP	5,5
	Gövde	112 M4
Flanşlar	DN1 (Emme) (mm)	65
	DN2 (Basma) (mm)	50
Boyut Ölçüsü (mm)	A	694
	B	394
	C	415
	L	1118
	lc	985
	lb	585
	K	62
	P	260
	Pa	320
	h1	190
h2	160	
Kaplin Ölçüsü ( $\phi$ ) (mm)	110	
Ağırlık (kg)	182	



## KSP 50-3

### Pompa Bilgileri

Pompa Tipi	KSP 50-3	Sızdırmazlık	Yumuşak Salmastra
Çark Çapı (mm) $\phi$	165-175	Yoğunluk (kg/m <sup>3</sup> )	1
Sıvı Cinsi	Su	Sıcaklık	-1°C- +110

### Motor Bilgileri

Güç (HP)	4
Voltaj (Volt)	380
Faz	3
Frekans (Hz)	50-60
Devir (rpm) (d/dk)	1500

$\phi$ 165		$\phi$ 175	
Q (m <sup>3</sup> /h)	Hm (m)	Q (m <sup>3</sup> /h)	Hm (m)
3	30	3	35
6	29	6	34
9	29	9	34
12	27	12	33
15	26	15	31
18	24	18	30
21	22	21	28
24	20	24	26
		27	23

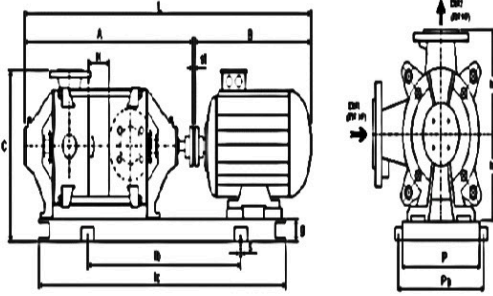

### KSP 50-3

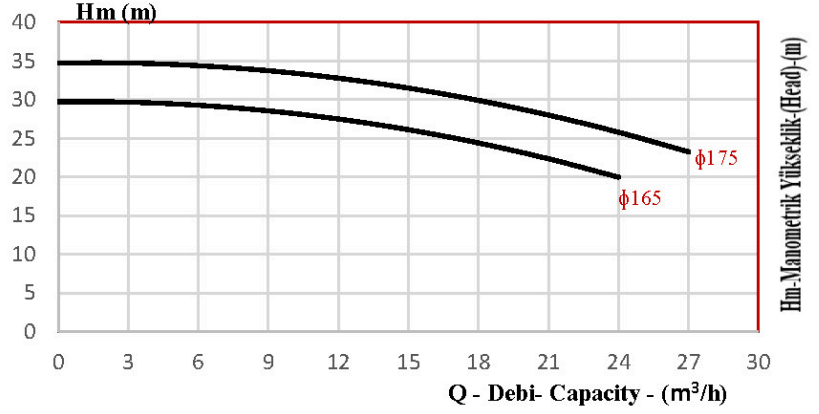

### KSP 50-3

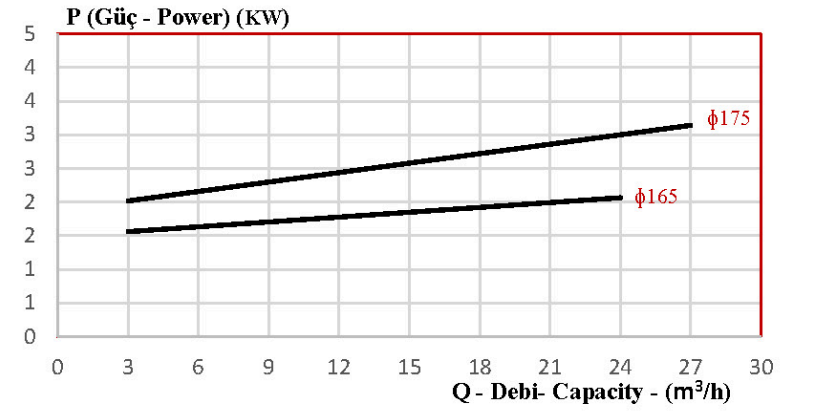

### KSP 50-3

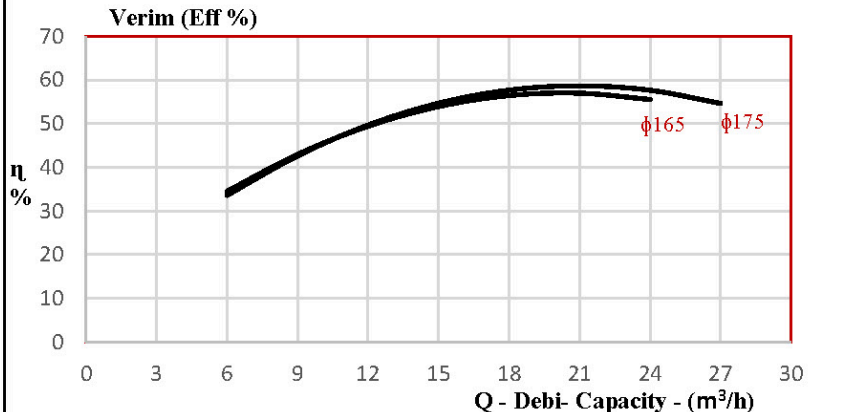

Pompa Tipi	KSP 50-3	
Kademe Sayısı	3	
Motor	HP	4
	Gövde	100 L4
Flanşlar	DN1 (Emme) (mm)	65
	DN2 (Basma) (mm)	50
Boyut Ölçüsü (mm)	A	632
	B	375
	C	415
	L	1037
	lc	915
	lb	515
	K	62
	P	260
	Pa	320
	h1	190
h2	160	
Kaplin Ölçüsü ( $\phi$ ) (mm)	95	
Ağırlık (kg)	158	

## KSP 50-2

### Pompa Bilgileri

Pompa Tipi	KSP 50-2	Sızdırmazlık	Yumuşak Salmastra
Çark Çapı (mm) $\phi$	165-175	Yoğunluk (kg/m <sup>3</sup> )	1
Sıvı Cinsi	Su	Sıcaklık	-1°C- +110

### Motor Bilgileri

Güç (HP)	3
Voltaj (Volt)	380
Faz	3
Frekans (Hz)	50-60
Devir (rpm) (d/dk)	1500

$\phi$ 165		$\phi$ 175	
Q (m <sup>3</sup> /h)	Hm (m)	Q (m <sup>3</sup> /h)	Hm (m)
3	20	3	23
6	20	6	23
9	19	9	22
12	18	12	22
15	17	15	21
18	16	18	20
21	15	21	19
24	13	24	17
		27	15

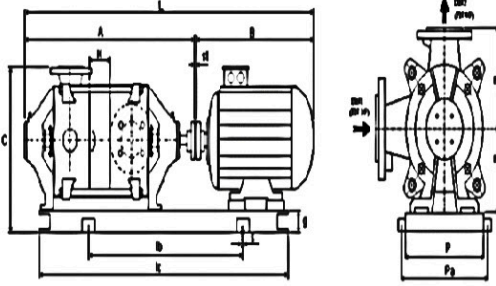

Pompa Tipi	KSP 50-2	
Kademe Sayısı	2	
Motor	HP	3
	Gövde	100 L4
Flanşlar	DN1 (Emme) (mm)	65
	DN2 (Basma) (mm)	50
Boyut Ölçüsü (mm)	A	570
	B	375
	C	415
	L	975
	lc	855
	lb	455
	K	62
	P	260
	Pa	320
	h1	190
h2	160	
Kaplin Ölçüsü ( $\phi$ ) (mm)	95	
Ağırlık (kg)	142	

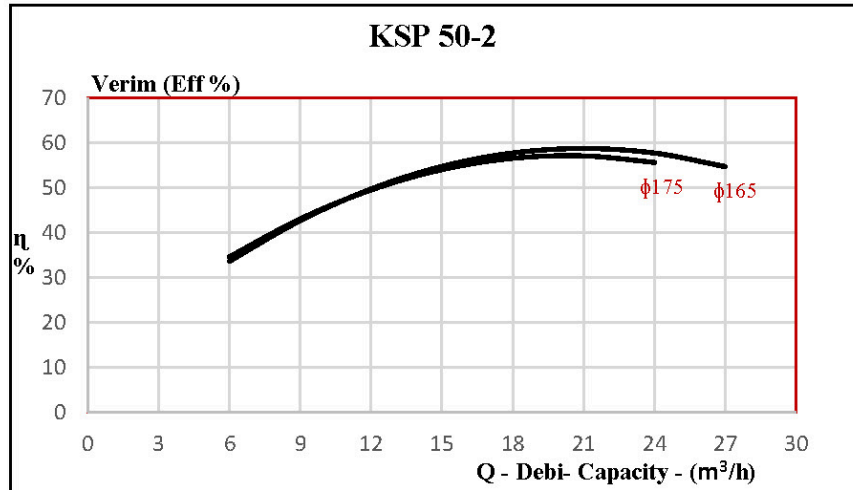
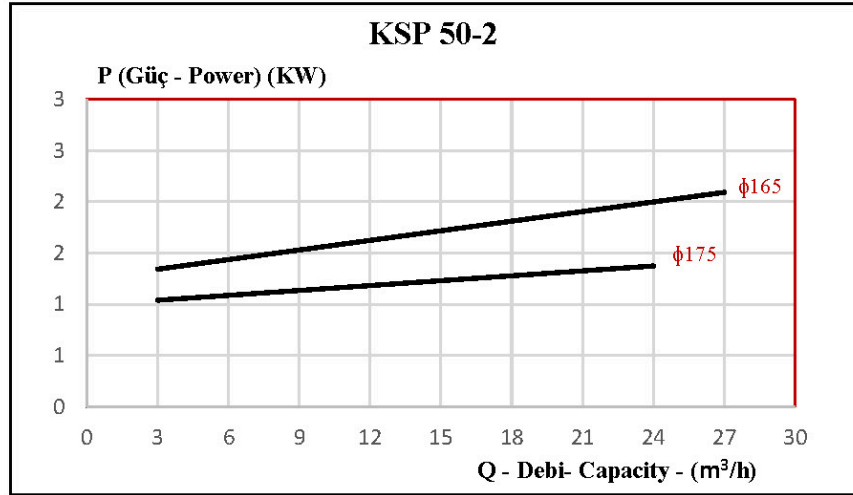
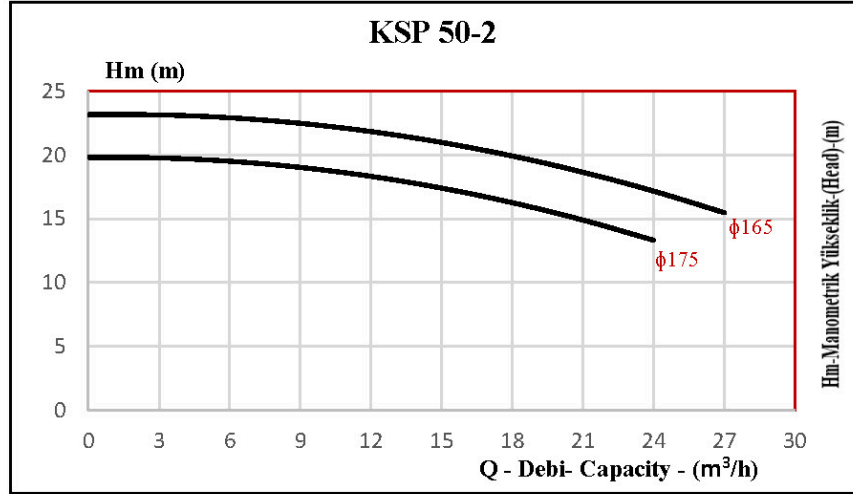

**ÇOK KADEMELİ POMPALAR**  
**KSP SERİSİ**  
**KSP 50-1**  
**1450 d/dk**

**TEK KADEME İÇİN KARAKTERİSTİK EĞRİLER**  
**Single Stage Performance Curves**

