

# KSP 40

- KSP 40-1
- KSP 40-2
- KSP 40-3
- KSP 40-4
- KSP 40-5
- KSP 40-6
- KSP 40-7
- KSP 40-8
- KSP 40-9
- KSP 40-10

KSP 40

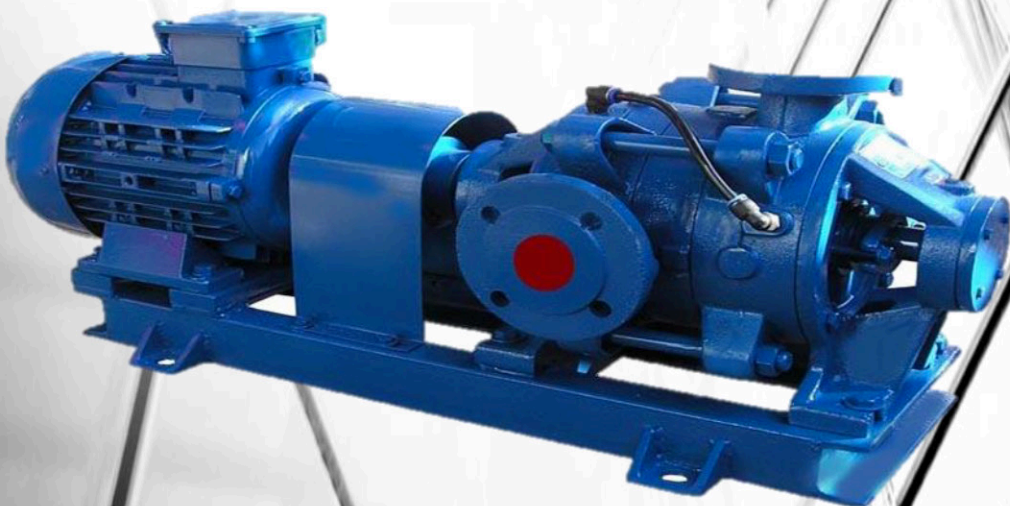

## KSP 40-10

Pompa Bilgileri			
Pompa Tipi	KSP 40-10	Sızdırmazlık	Yumuşak Salmastra
Çark Çapı (mm) $\phi$	135-145-160	Yoğunluk (kg/m <sup>3</sup> )	1
Sıvı Cinsi	Su	Sıcaklık	-1°C- +110

Motor Bilgileri	
Güç (HP)	60
Voltaj (Volt)	380
Faz	3
Frekans (Hz)	50-60
Devir (rpm) (d/dk)	3000

$\phi$ 135		$\phi$ 140		$\phi$ 160	
Q (m <sup>3</sup> /h)	Hm (m)	Q (m <sup>3</sup> /h)	Hm (m)	Q (m <sup>3</sup> /h)	Hm (m)
5	239	5	295	5	357
10	230	10	286	10	350
15	214	15	270	15	336
20	192	20	249	20	316
25	163	25	222	25	290
30	128	30	188	30	257
35	86	35	149	35	218
		40	104	40	173
		45	121	45	121

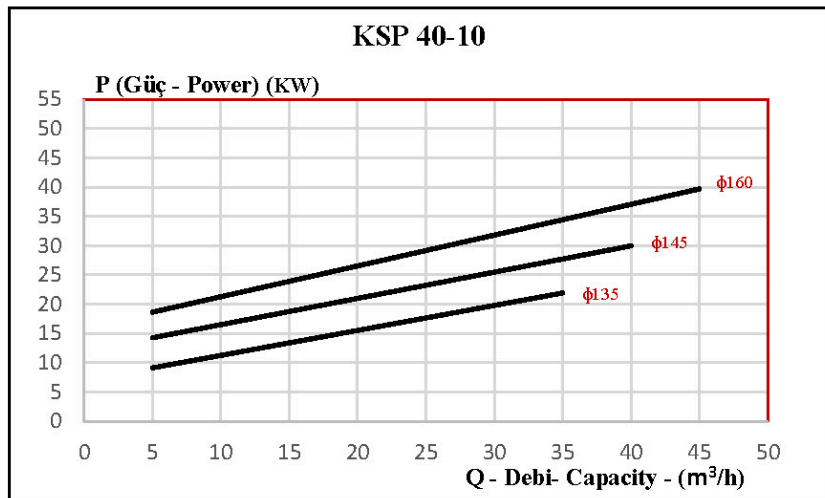
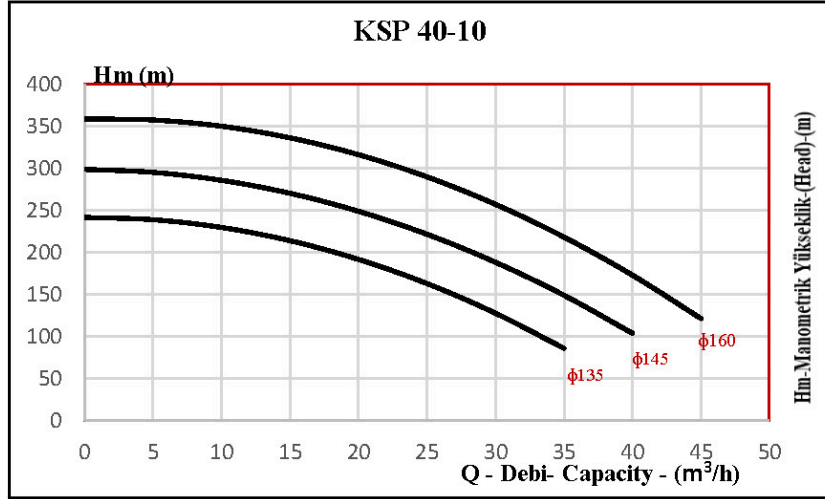
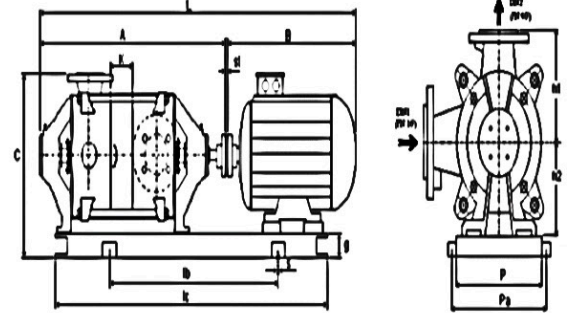

Pompa Tipi	KSP 40-10	
Kademe Sayısı	10	
Motor	HP	60
	Gövde	225 M2
Flanşlar	DN1 (Emme) (mm)	50
	DN2 (Basma) (mm)	40
Boyut Ölçüsü (mm)	A	972
	B	790
	C	505
	L	1807
	lc	1575
	lb	1175
	K	55
	P	436
	Pa	496
	h1	185
h2	160	
Kaplin Ölçüsü ( $\phi$ ) (mm)	160	
Ağırlık (kg)	542	

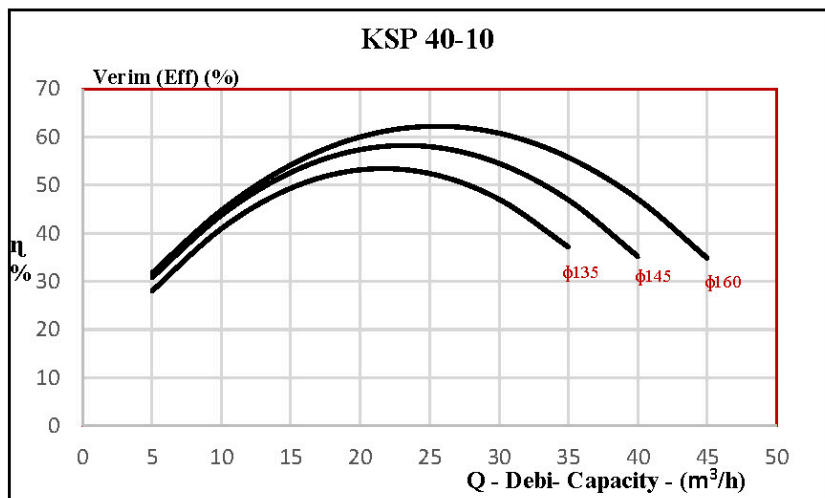

## KSP 40-9

Pompa Bilgileri				Motor Bilgileri	
Pompa Tipi	KSP 40-9	Sızdırmazlık	Yumuşak Salmastra	Güç (HP)	50
Çark Çapı (mm) $\phi$	135-145-160	Yoğunluk (kg/m <sup>3</sup> )	1	Voltaj (Volt)	380
Sıvı Cinsi	Su	Sıcaklık	-1°C- +110	Faz	3
				Frekans (Hz)	50-60
				Devir (rpm) (d/dk)	3000

$\phi$ 135		$\phi$ 140		$\phi$ 160	
Q (m <sup>3</sup> /h)	Hm (m)	Q (m <sup>3</sup> /h)	Hm (m)	Q (m <sup>3</sup> /h)	Hm (m)
5	215	5	266	5	322
10	207	10	257	10	315
15	193	15	243	15	303
20	173	20	224	20	285
25	147	25	199	25	261
30	115	30	169	30	231
35	78	35	134	35	196
		40	93	40	156
		45	109	45	109

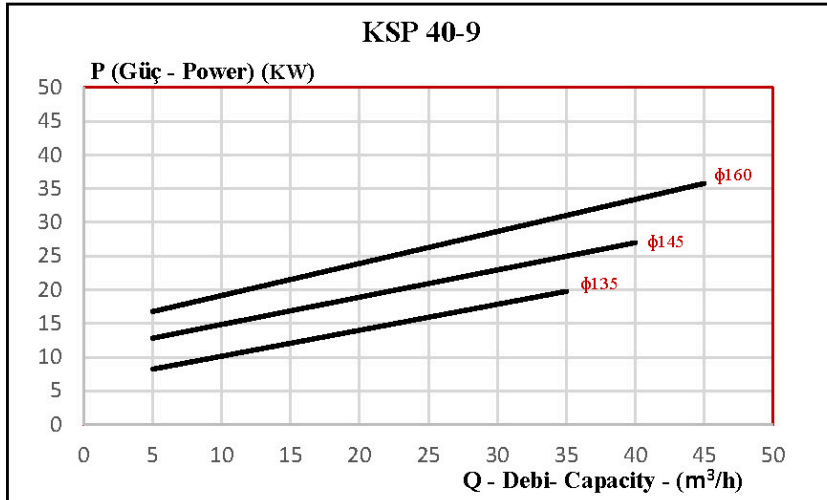
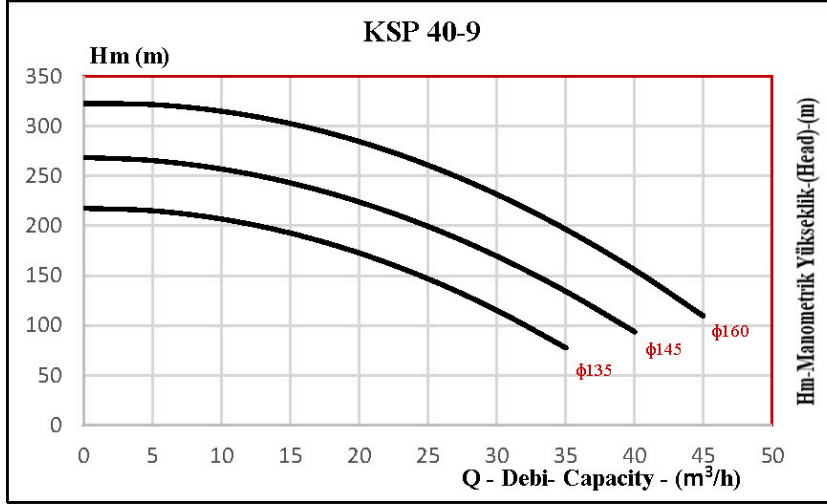
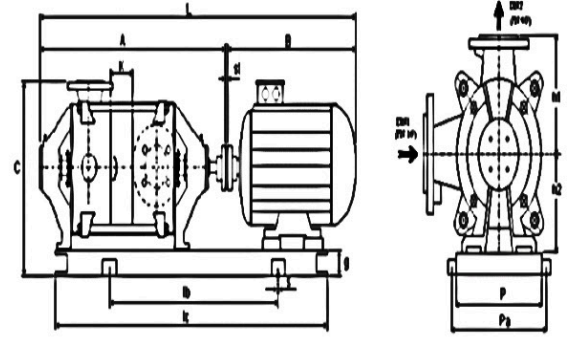

Pompa Tipi		KSP 40-9
Kademe Sayısı		9
Motor	HP	50
	Gövde	200 L2
Flanşlar	DN1 (Emme) (mm)	50
	DN2 (Basma) (mm)	40
Boyut Ölçüsü (mm)	A	917
	B	747
	C	485
	L	1709
	lc	1490
	lb	1090
	K	55
	P	400
	Pa	460
	h1	185
h2	160	
Kaplin Ölçüsü ( $\phi$ ) (mm)		160
Ağırlık (kg)		452

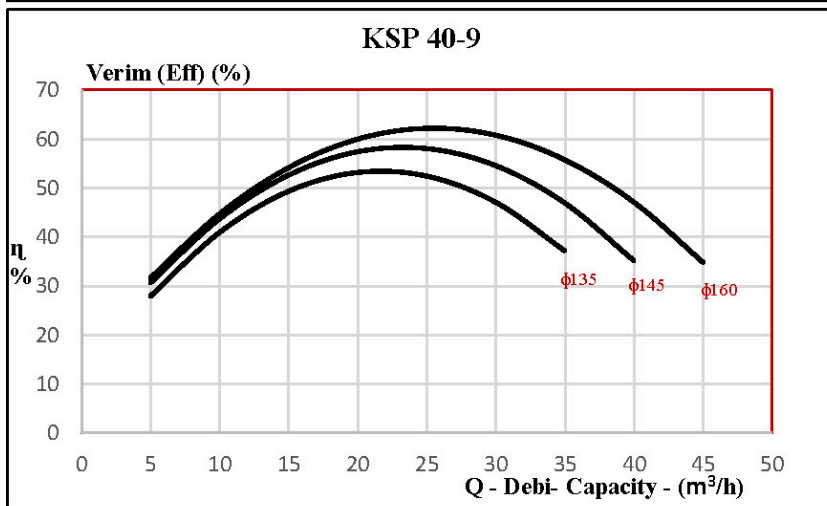

## KSP 40-8

### Pompa Bilgileri

Pompa Tipi	KSP 40-8	Sızdırmazlık	Yumuşak Salmastra
Çark Çapı (mm) $\phi$	135-145-160	Yoğunluk (kg/m <sup>3</sup> )	1
Sıvı Cinsi	Su	Sıcaklık	-1°C- +110

### Motor Bilgileri

Güç (HP)	40
Voltaj (Volt)	380
Faz	3
Frekans (Hz)	50-60
Devir (rpm) (d/dk)	3000

$\phi$ 135		$\phi$ 140		$\phi$ 160	
Q (m <sup>3</sup> /h)	Hm (m)	Q (m <sup>3</sup> /h)	Hm (m)	Q (m <sup>3</sup> /h)	Hm (m)
5	191	5	236	5	286
10	184	10	229	10	280
15	171	15	216	15	269
20	154	20	199	20	253
25	131	25	177	25	232
30	102	30	151	30	206
35	69	35	119	35	175
		40	83	40	138
				45	97

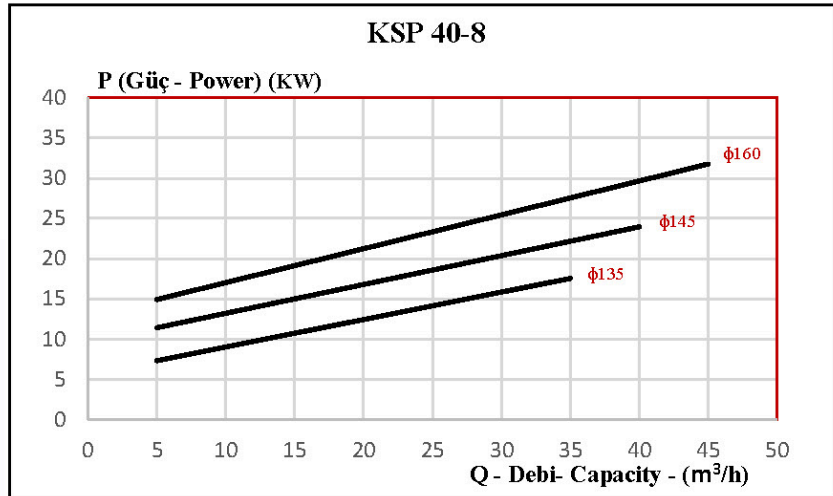
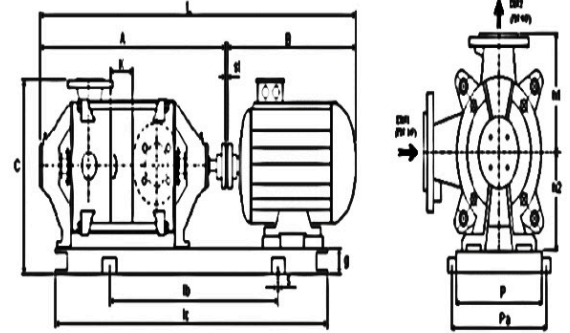
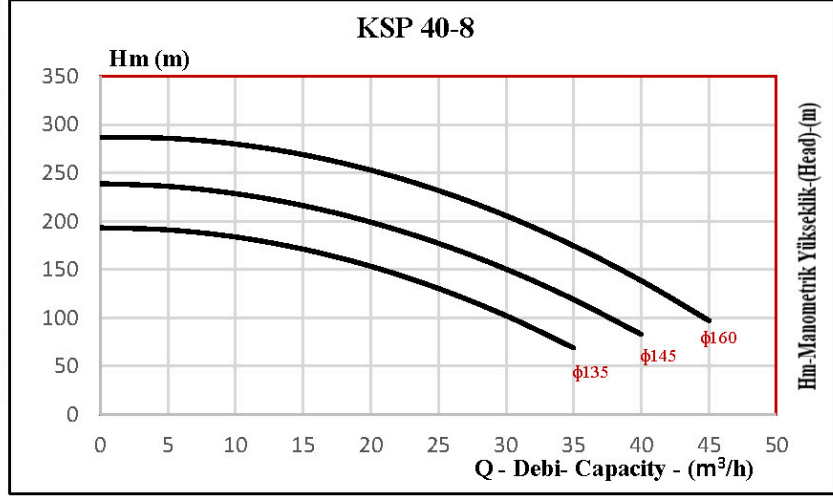

Pompa Tipi	KSP 40-8	
Kademe Sayısı	8	
Motor	HP	40
	Gövde	200 L2
Flanşlar	DN1 (Emme) (mm)	50
	DN2 (Basma) (mm)	40
Boyut Ölçüsü (mm)	A	862
	B	747
	C	485
	L	1649
	lc	1430
	lb	1030
	K	55
	P	400
	Pa	460
	h1	185
h2	160	
Kaplin Ölçüsü ( $\phi$ ) (mm)	140	
Ağırlık (kg)	418	

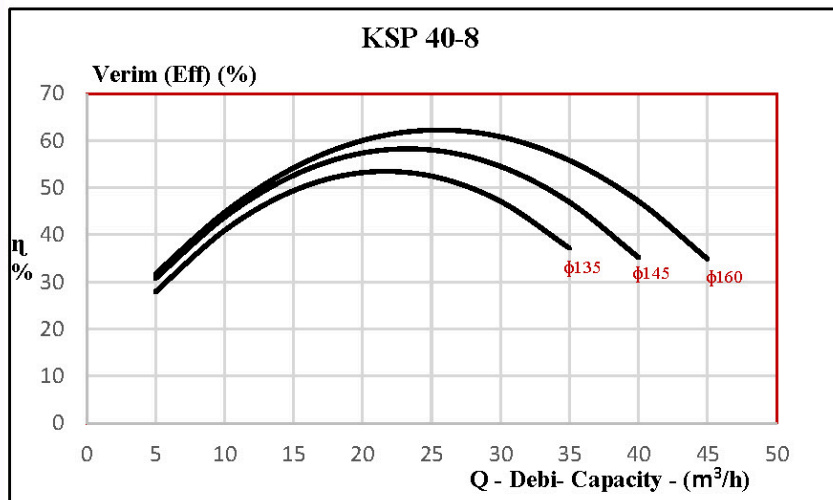

## KSP 40-7

### Pompa Bilgileri

Pompa Tipi	KSP 40-7	Sızdırmazlık	Yumuşak Salmastra
Çark Çapı (mm) $\phi$	135-145-160	Yoğunluk (kg/m <sup>3</sup> )	1
Sıvı Cinsi	Su	Sıcaklık	-1°C- +110

### Motor Bilgileri

Güç (HP)	40
Voltaj (Volt)	380
Faz	3
Frekans (Hz)	50-60
Devir (rpm) (d/dk)	3000

$\phi$ 135		$\phi$ 140		$\phi$ 160	
Q (m <sup>3</sup> /h)	Hm (m)	Q (m <sup>3</sup> /h)	Hm (m)	Q (m <sup>3</sup> /h)	Hm (m)
5	167	5	207	5	250
10	161	10	200	10	245
15	150	15	189	15	235
20	134	20	174	20	221
25	114	25	155	25	203
30	90	30	132	30	180
35	60	35	104	35	153
		40	73	40	121
				45	85

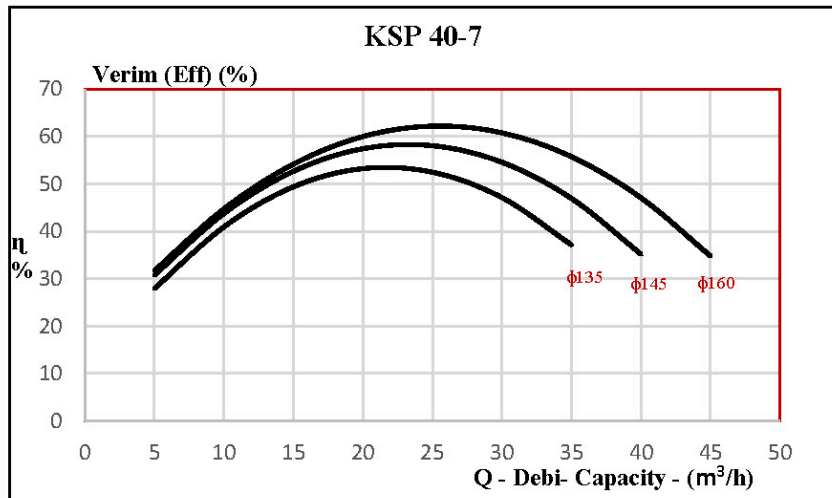
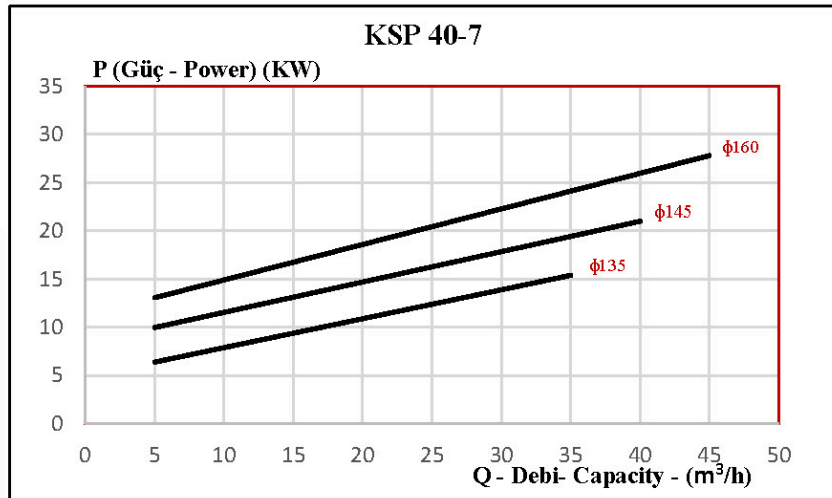
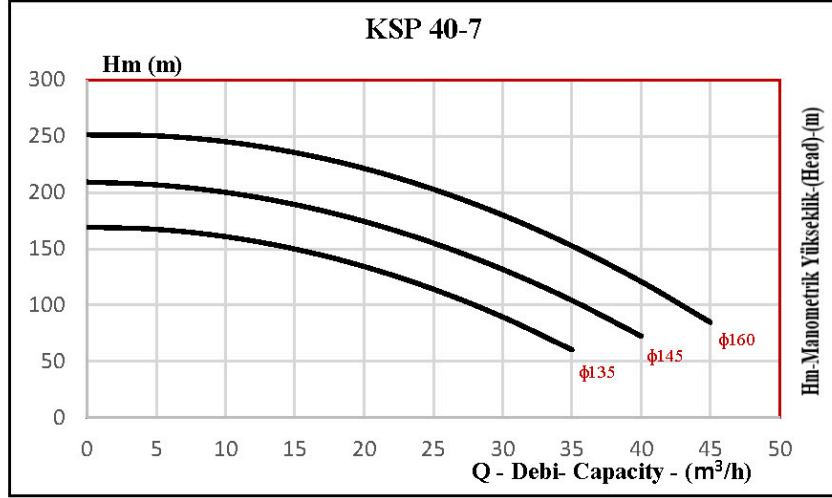
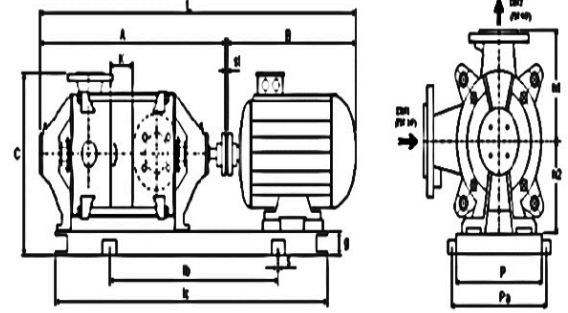

Pompa Tipi	KSP 40-7	
Kademe Sayısı	7	
Motor	HP	40
	Gövde	200 L2
Flanşlar	DN1 (Emme) (mm)	50
	DN2 (Basma) (mm)	40
Boyut Ölçüsü (mm)	A	807
	B	747
	C	485
	L	1506
	lc	1375
	lb	975
	K	55
	P	400
	Pa	460
	h1	185
h2	160	
Kaplin Ölçüsü ( $\phi$ ) (mm)	140	
Ağırlık (kg)	405	

## KSP 40-6

### Pompa Bilgileri

Pompa Tipi	KSP 40-6	Sızdırmazlık	Yumuşak Salmastra
Çark Çapı (mm) $\phi$	135-145-160	Yoğunluk (kg/m <sup>3</sup> )	1
Sıvı Cinsi	Su	Sıcaklık	-1°C- +110

### Motor Bilgileri

Güç (HP)	30
Voltaj (Volt)	380
Faz	3
Frekans (Hz)	50-60
Devir (rpm) (d/dk)	3000

$\phi$ 135		$\phi$ 140		$\phi$ 160	
Q (m <sup>3</sup> /h)	Hm (m)	Q (m <sup>3</sup> /h)	Hm (m)	Q (m <sup>3</sup> /h)	Hm (m)
5	143	5	177	5	214
10	138	10	171	10	210
15	128	15	162	15	202
20	115	20	149	20	190
25	98	25	133	25	174
30	77	30	113	30	154
35	52	35	89	35	131
		40	62	40	104
				45	73

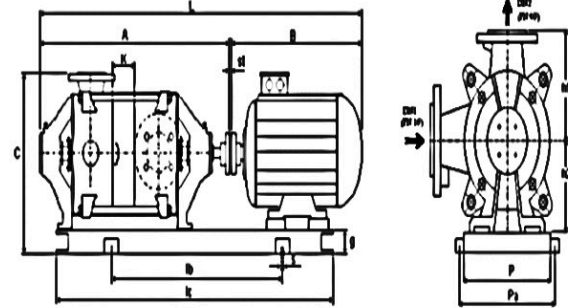

Pompa Tipi	KSP 40-6	
Kademe Sayısı	6	
Motor	HP	30
	Gövde	180 M2
Flanşlar	DN1 (Emme) (mm)	50
	DN2 (Basma) (mm)	40
Boyut Ölçüsü (mm)	A	752
	B	659
	C	465
	L	1446
	lc	1245
	lb	845
	K	55
	P	355
	Pa	415
	h1	185
h2	160	
Kaplin Ölçüsü ( $\phi$ ) (mm)	140	
Ağırlık (kg)	332	

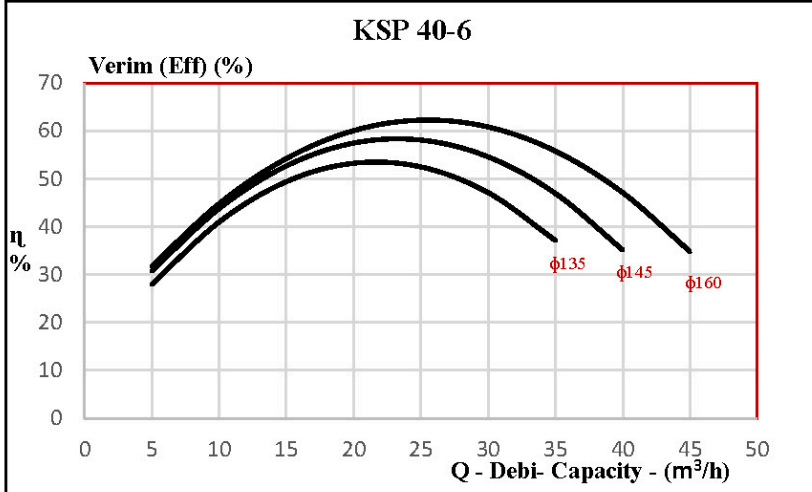
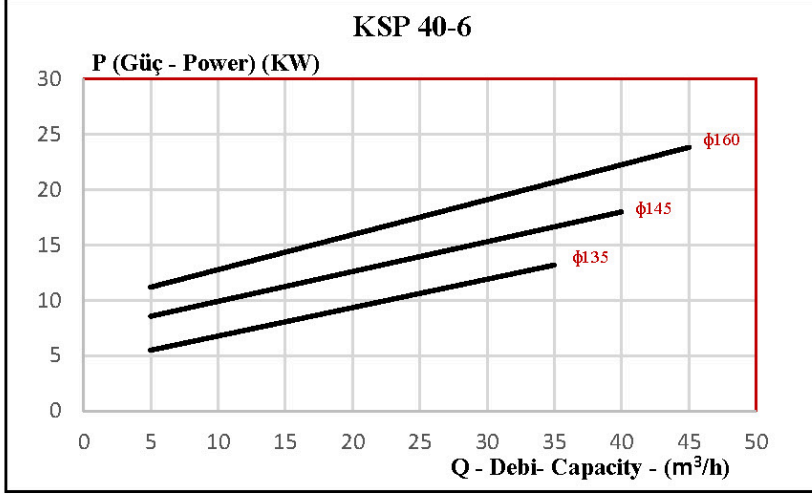
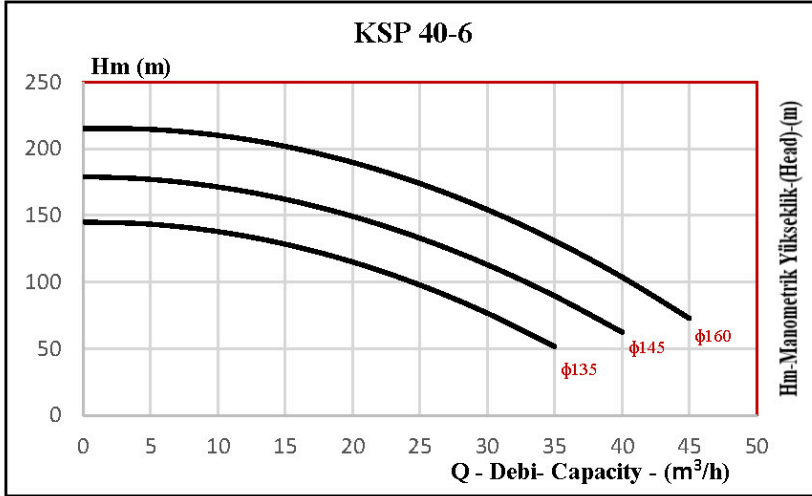

## KSP 40-5

### Pompa Bilgileri

Pompa Tipi	KSP 40-5	Sızdırmazlık	Yumuşak Salmastra
Çark Çapı (mm) $\phi$	135-145-160	Yoğunluk (kg/m <sup>3</sup> )	1
Sıvı Cinsi	Su	Sıcaklık	-1°C- +110

### Motor Bilgileri

Güç (HP)	25
Voltaj (Volt)	380
Faz	3
Frekans (Hz)	50-60
Devir (rpm) (d/dk)	3000

$\phi$ 135		$\phi$ 140		$\phi$ 160	
Q (m <sup>3</sup> /h)	Hm (m)	Q (m <sup>3</sup> /h)	Hm (m)	Q (m <sup>3</sup> /h)	Hm (m)
5	120	5	148	5	179
10	115	10	143	10	175
15	107	15	135	15	168
20	96	20	124	20	158
25	82	25	111	25	145
30	64	30	94	30	129
35	43	35	75	35	109
		40	52	40	86
				45	61

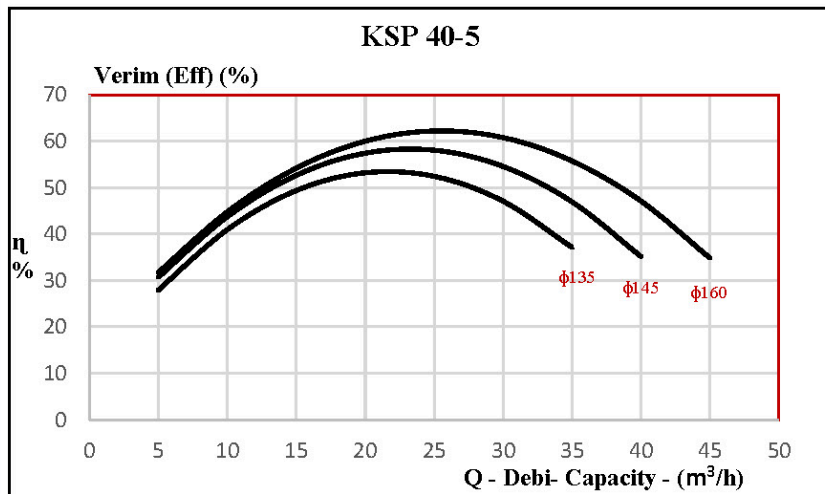
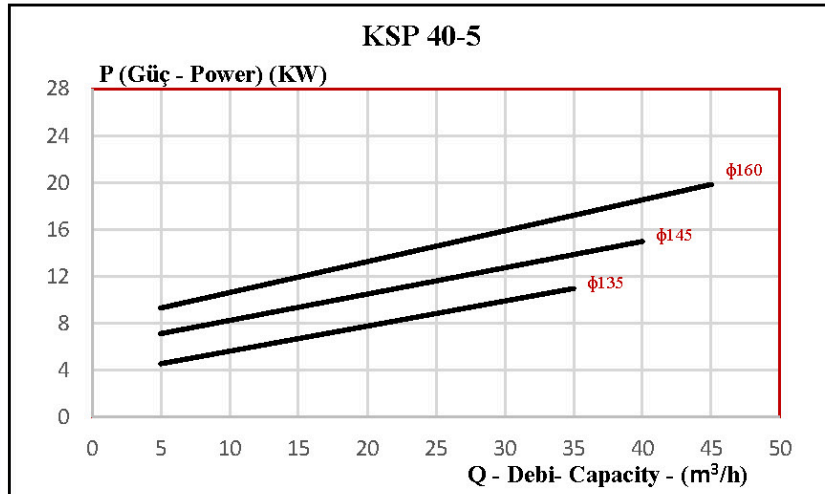
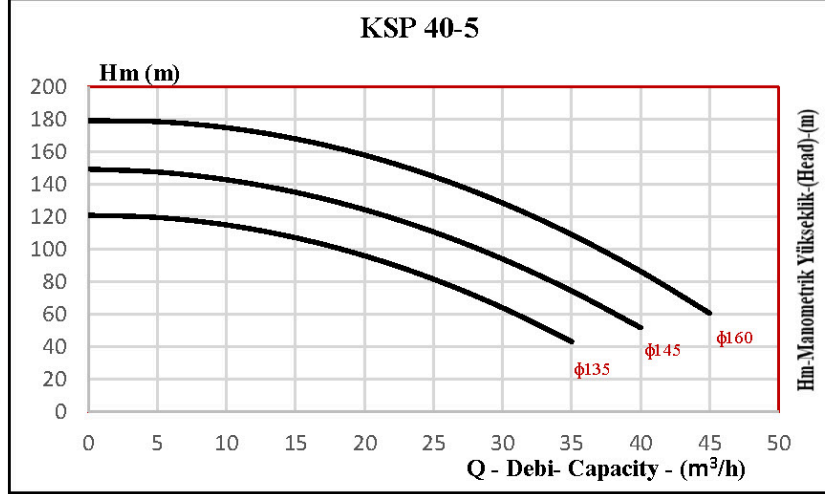
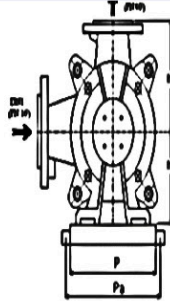
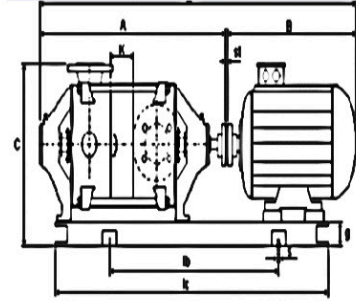

Pompa Tipi	KSP 40-5	
Kademe Sayısı	5	
Motor	HP	25
	Gövde	160 L2
Flanşlar	DN1 (Emme) (mm)	50
	DN2 (Basma) (mm)	40
Boyut Ölçüsü (mm)	A	697
	B	645
	C	425
	L	1377
	lc	1185
	lb	785
	K	55
	P	315
	Pa	372
	h1	185
	h2	160
Kaplin Ölçüsü (φ) (mm)	125	
Ağırlık (kg)	268	

## KSP 40-4

### Pompa Bilgileri

Pompa Tipi	KSP 40-4	Sızdırmazlık	Yumuşak Salmastra
Çark Çapı (mm) $\phi$	135-145-160	Yoğunluk (kg/m <sup>3</sup> )	1
Sıvı Cinsi	Su	Sıcaklık	-1°C- +110

### Motor Bilgileri

Güç (HP)	20
Voltaj (Volt)	380
Faz	3
Frekans (Hz)	50-60
Devir (rpm) (d/dk)	3000

$\phi$ 135		$\phi$ 140		$\phi$ 160	
Q (m <sup>3</sup> /h)	Hm (m)	Q (m <sup>3</sup> /h)	Hm (m)	Q (m <sup>3</sup> /h)	Hm (m)
5	96	5	118	5	143
10	92	10	114	10	140
15	86	15	108	15	135
20	77	20	100	20	126
25	65	25	89	25	116
30	51	30	75	30	103
35	34	35	60	35	87
		40	42	40	69
				45	49

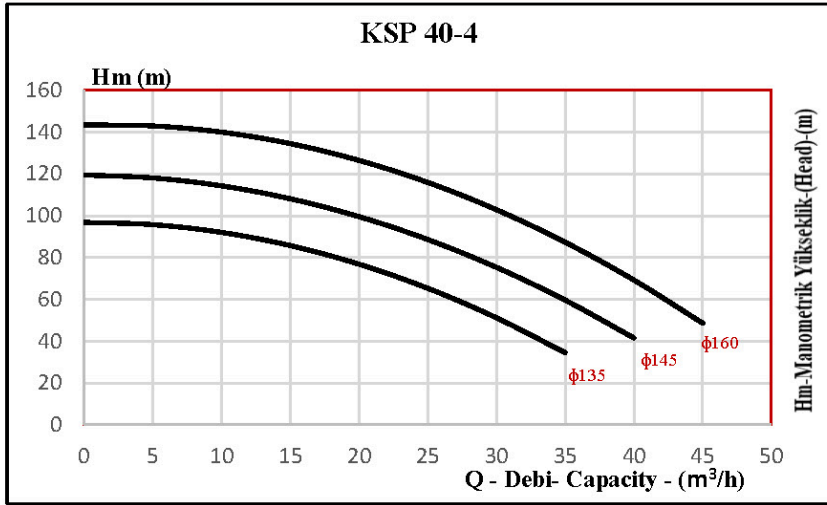
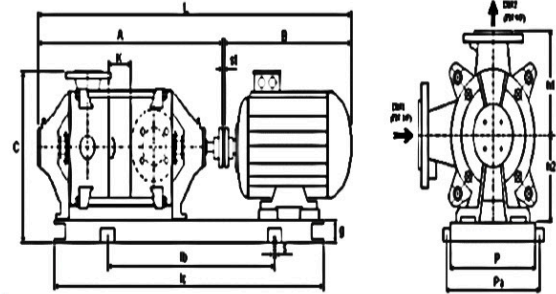

Pompa Tipi	KSP 40-4	
Kademe Sayısı	4	
Motor	HP	20
	Gövde	160 M2
Flanşlar	DN1 (Emme) (mm)	50
	DN2 (Basma) (mm)	40
Boyut Ölçüsü (mm)	A	642
	B	601
	C	425
	L	1278
	lc	1085
	lb	685
	K	55
	P	315
	Pa	372
	h1	185
h2	160	
Kaplin Ölçüsü ( $\phi$ ) (mm)	125	
Ağırlık (kg)	239	

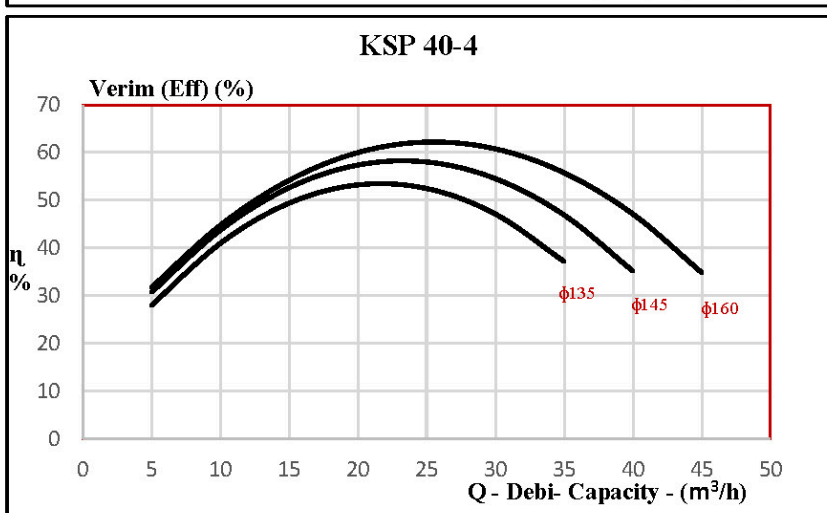
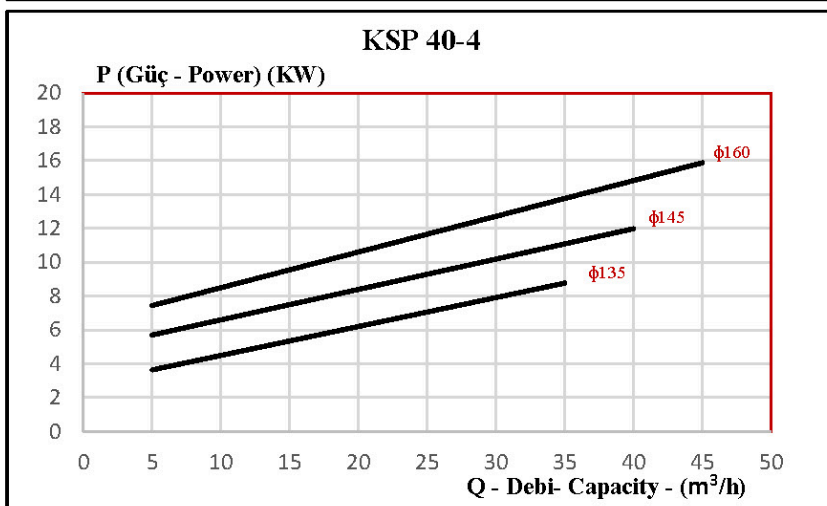



## KSP 40-3

### Pompa Bilgileri

Pompa Tipi	KSP 40-3	Sızdırmazlık	Yumuşak Salmastra
Çark Çapı (mm) $\phi$	135-145-160	Yoğunluk (kg/m <sup>3</sup> )	1
Sıvı Cinsi	Su	Sıcaklık	-1°C- +110

### Motor Bilgileri

Güç (HP)	15
Voltaj (Volt)	380
Faz	3
Frekans (Hz)	50-60
Devir (rpm) (d/dk)	3000

$\phi$ 135		$\phi$ 140		$\phi$ 160	
Q (m <sup>3</sup> /h)	Hm (m)	Q (m <sup>3</sup> /h)	Hm (m)	Q (m <sup>3</sup> /h)	Hm (m)
5	72	5	89	5	107
10	69	10	86	10	105
15	64	15	81	15	101
20	58	20	75	20	95
25	49	25	66	25	87
30	38	30	56	30	77
35	26	35	45	35	65
		40	31	40	52
				45	36

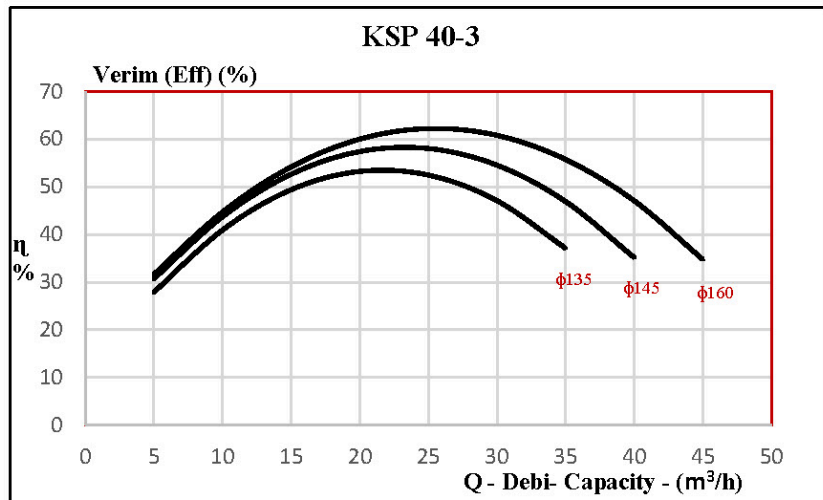
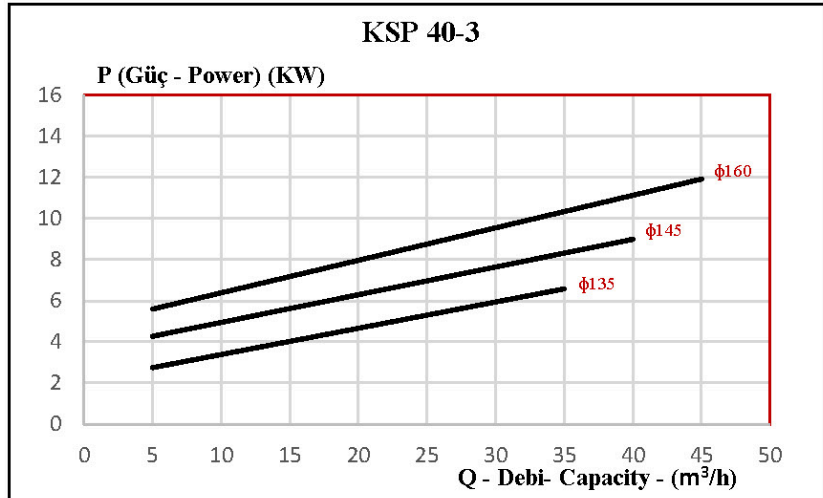
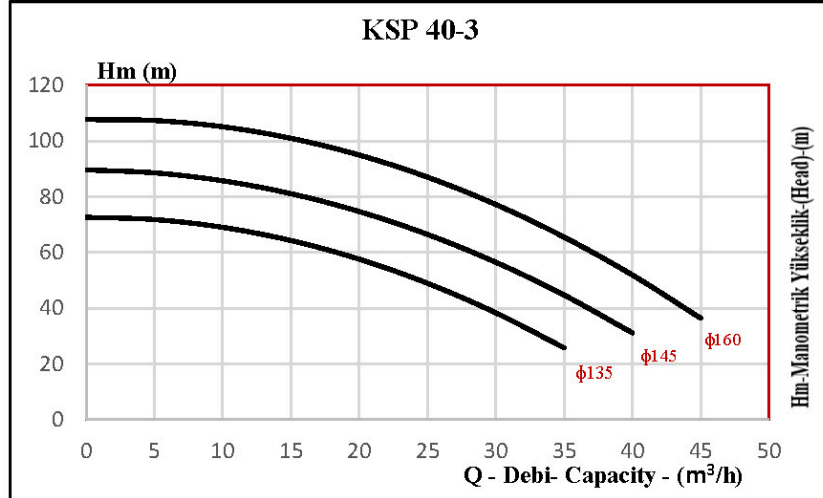
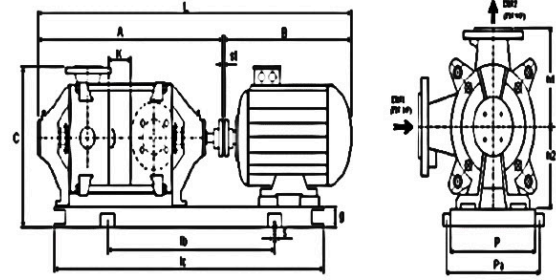

Pompa Tipi	KSP 40-3	
Kademe Sayısı	3	
Motor	HP	15
	Gövde	160 M2
Flanşlar	DN1 (Emme) (mm)	50
	DN2 (Basma) (mm)	40
Boyut Ölçüsü (mm)	A	587
	B	601
	C	425
	L	1223
	lc	1030
	lb	630
	K	55
	P	315
	Pa	372
	h1	185
	h2	160
Kaplin Ölçüsü ( $\phi$ ) (mm)	125	
Ağırlık (kg)	215	

## KSP 40-2

Pompa Bilgileri			
Pompa Tipi	KSP 40-2	Sızdırmazlık	Yumuşak Salmastra
Çark Çapı (mm) $\phi$	135-145-160	Yoğunluk (kg/m <sup>3</sup> )	1
Sıvı Cinsi	Su	Sıcaklık	-1°C- +110

Motor Bilgileri	
Güç (HP)	7,5-10
Voltaj (Volt)	380
Faz	3
Frekans (Hz)	50-60
Devir (rpm) (d/dk)	3000

$\phi$ 135		$\phi$ 140		$\phi$ 160	
Q (m <sup>3</sup> /h)	Hm (m)	Q (m <sup>3</sup> /h)	Hm (m)	Q (m <sup>3</sup> /h)	Hm (m)
5	48	5	57	5	71
10	46	10	55	10	70
15	43	15	52	15	67
20	38	20	48	20	63
25	33	25	42	25	58
30	26	30	36	30	51
35	17	35	28	35	44
		40	19	40	35
				45	24

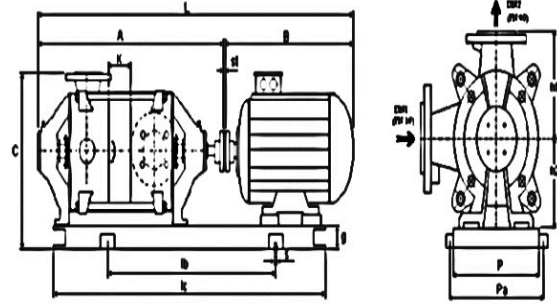

Pompa Tipi	KSP 40-2	
Kademe Sayısı	2	
Motor	HP	7,5 10
	Gövde	132 S2 132 S2
Flanşlar	DN1 (Emme) (mm)	50
	DN2 (Basma) (mm)	40
Boyut Ölçüsü (mm)	A	532 532
	B	455 455
	C	410 410
	L	1017 1017
	lc	845 845
	lb	445 445
	K	55 55
	P	260 260
	Pa	320 320
	h1	185 185
h2	160 160	
Kaplin Ölçüsü ( $\phi$ ) (mm)	110	110
Ağırlık (kg)	130	135

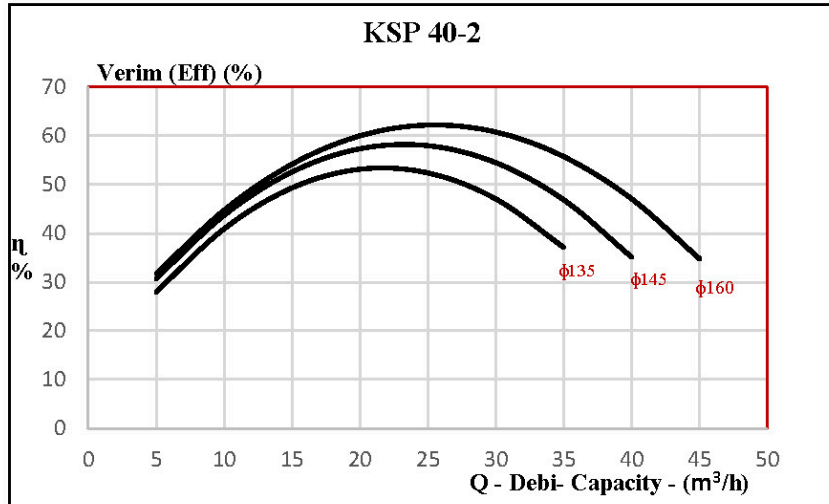
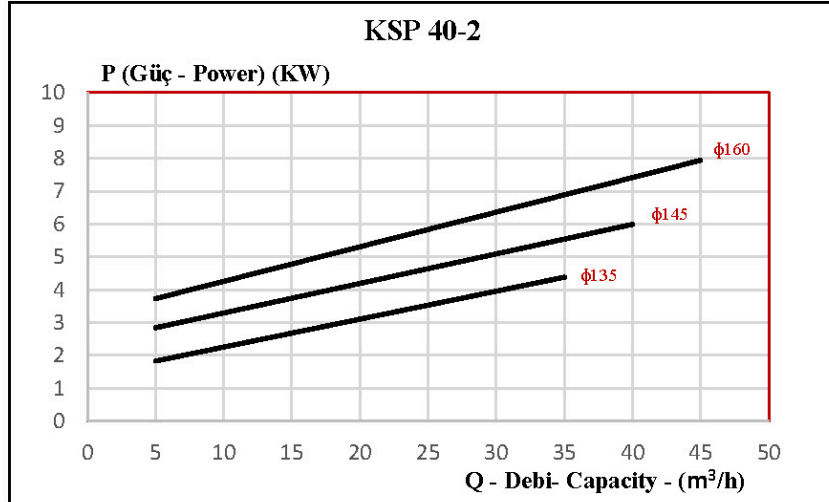
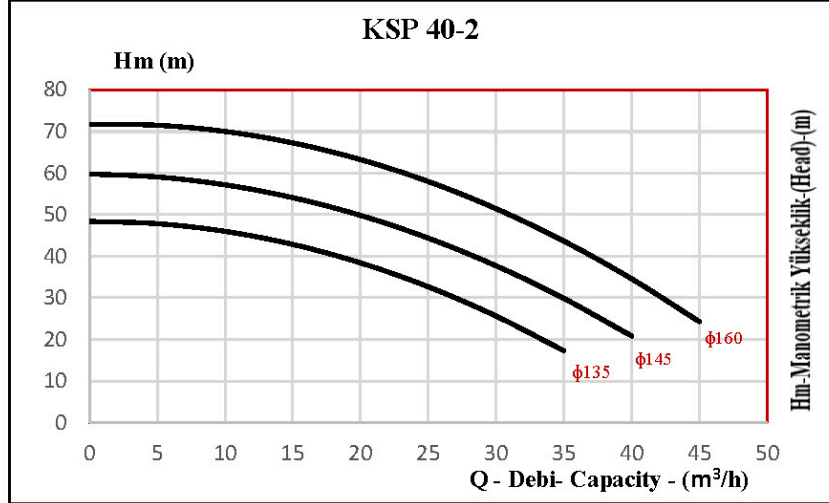

**ÇOK KADEMELİ POMPALAR**  
**KSP SERİSİ**  
**KSP 40-1**  
**2950 d/dk**

**TEK KADEME İÇİN KARAKTERİSTİK EĞRİLER**  
**Single Stage Performance Curves**

